

NASA/TM-2019-220355

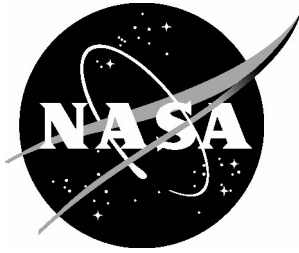

# Airspace Technology Demonstration 2 (ATD-2) Technology Description Document (TDD)

*Ehsan Talebi  
Millenium Engineering & Integration Co.  
Ames Research Center, Moffett Field, California*

*Andrew Ging, Shawn Engelland, Al Capps, Michelle Eshow, Yoon Jung, Shivanjli Sharma  
Ames Research Center, Moffett Field, California*

*Michael Downs, Cynthia Freedman, Tyler Ngo, Hank Sielski, Easter Wang  
Universities Space Research Assn.  
Ames Research Center, Moffett Field, California*

*Jason Burke, Shawn Gorman, Brian Phipps, Isaac Robeson, Stuart Wilson  
Mosaic ATM, Inc.  
Ames Research Center, Moffett Field, California*

*Louise Morgan-Ruszkowski  
KBRWyle/Parallel Innovations  
Ames Research Center, Moffett Field, California*

## NASA STI Program . . . in Profile

Since its founding, NASA has been dedicated to the advancement of aeronautics and space science. The NASA scientific and technical information (STI) program plays a key part in helping NASA maintain this important role.

The NASA STI program operates under the auspices of the Agency Chief Information Officer. It collects, organizes, provides for archiving, and disseminates NASA's STI. The NASA STI program provides access to the NASA Aeronautics and Space Database and its public interface, the NASA Technical Report Server, thus providing one of the largest collections of aeronautical and space science STI in the world. Results are published in both non-NASA channels and by NASA in the NASA STI Report Series, which includes the following report types:

- TECHNICAL PUBLICATION. Reports of completed research or a major significant phase of research that present the results of NASA programs and include extensive data or theoretical analysis. Includes compilations of significant scientific and technical data and information deemed to be of continuing reference value. NASA counterpart of peer-reviewed formal professional papers, but having less stringent limitations on manuscript length and extent of graphic presentations.
- TECHNICAL MEMORANDUM. Scientific and technical findings that are preliminary or of specialized interest, e.g., quick release reports, working papers, and bibliographies that contain minimal annotation. Does not contain extensive analysis.
- CONTRACTOR REPORT. Scientific and technical findings by NASA-sponsored contractors and grantees.
- CONFERENCE PUBLICATION. Collected papers from scientific and technical conferences, symposia, seminars, or other meetings sponsored or co-sponsored by NASA.
- SPECIAL PUBLICATION. Scientific, technical, or historical information from NASA programs, projects, and missions, often concerned with subjects having substantial public interest.
- TECHNICAL TRANSLATION. English-language translations of foreign scientific and technical material pertinent to NASA's mission.

Specialized services also include creating custom thesauri, building customized databases, and organizing and publishing research results.

For more information about the NASA STI program, see the following:

- Access the NASA STI program home page at <http://www.sti.nasa.gov>
- E-mail your question via the Internet to [help@sti.nasa.gov](mailto:help@sti.nasa.gov)
- Fax your question to the NASA STI Help Desk at 443-757-5803
- Phone the NASA STI Help Desk at 443-757-5802
- Write to:  
NASA STI Help Desk  
NASA Center for AeroSpace Information  
7115 Standard Drive  
Hanover, MD 21076-1320

NASA/TM-2019-220355

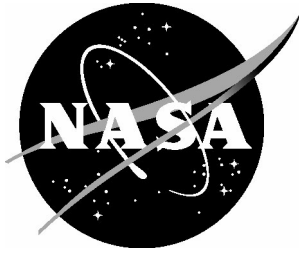

# Airspace Technology Demonstration 2 (ATD-2) Technology Description Document (TDD)

*Ehsan Talebi  
Millenium Engineering & Integration Co.  
Ames Research Center, Moffett Field, California*

*Andrew Ging, Shawn Engelland, Al Capps, Michelle Eshow, Yoon Jung, Shivanjli Sharma  
Ames Research Center, Moffett Field, California*

*Michael Downs, Cynthia Freedman, Tyler Ngo, Hank Sielski, Easter Wang  
Universities Space Research Assn.  
Ames Research Center, Moffett Field, California*

*Jason Burke, Shawn Gorman, Brian Phipps, Isaac Robeson, Stuart Wilson  
Mosaic ATM, Inc.  
Ames Research Center, Moffett Field, California*

*Louise Morgan-Ruszkowski  
KBRWyle/Parallel Innovations  
Ames Research Center, Moffett Field, California*

National Aeronautics and  
Space Administration

Ames Research Center  
Moffett Field, California 94035-1000

---

September 2019

Available from:

NASA Center for AeroSpace Information  
7115 Standard Drive  
Hanover, MD 21076-1320

National Technical Information Service  
5301 Shawnee Road  
Alexandria, VA 22312

This report is also available in electronic form at  
<http://www.aviationsystemsdivision.arc.nasa.gov/>



# Table of Contents

<b>1</b>	<b>INTRODUCTION .....</b>	<b>1</b>
1.1	IDENTIFICATION .....	1
1.2	BACKGROUND.....	2
1.3	DOCUMENT PURPOSE AND SCOPE .....	2
1.4	DOCUMENT ORGANIZATION.....	2
<b>2</b>	<b>TECHNOLOGIES CONTRIBUTING TO ATD-2 .....</b>	<b>4</b>
2.1	FAA CONTRIBUTING TECHNOLOGIES .....	4
2.1.1	Traffic Flow Management System (TFMS).....	6
2.1.2	Time Based Flow Management (TBFM).....	8
2.1.3	Terminal Flight Data Manager (TFDM).....	10
2.1.4	System Wide Information Management (SWIM) .....	14
2.2	NASA CONTRIBUTING TECHNOLOGIES.....	15
2.2.1	Spot and Runway Departure Advisor (SARDA).....	15
2.2.2	Precision Departure Release Capability (PDRC).....	16
<b>3</b>	<b>OPERATIONAL VIEW OF ATD-2.....</b>	<b>18</b>
3.1	TACTICAL DEPARTURE SCHEDULING .....	19
3.2	METROPLEX PLANNER (MP) SYSTEM.....	19
3.3	STRATEGIC SURFACE SCHEDULING FOR SURFACE COLLABORATIVE DECISION MAKING (SURFACE CDM).....	20
3.4	TACTICAL SURFACE SCHEDULING .....	20
3.5	TOWER ELECTRONIC FLIGHT DATA (EFD).....	20
<b>4</b>	<b>SYSTEM VIEW OF ATD-2.....</b>	<b>22</b>
4.1	SURFACE TRAJECTORY BASED OPERATIONS (STBO).....	23
4.1.1	Surface Modeler .....	24
4.1.2	Surface Scheduler .....	29
4.1.3	Surface Metering Program (SMP) Service.....	34
4.1.4	TFDM/TTP SWIM.....	38
4.1.5	Fuser .....	40
4.1.6	Traffic Flow Data (TFD) Management.....	46
4.1.7	Airport Resource Management (ARM) .....	46
4.1.8	EFD/AEFS .....	47
4.1.9	Surface Situational Display/STBO Client.....	49
4.1.10	Flight Traffic Management Initiative (TMI) Service.....	51
4.2	METROPLEX PLANNER (MP).....	54
4.3	TIME BASED FLOW MANAGEMENT.....	54
4.3.1	Information Flow from TBFM to IADS .....	56
4.3.2	Information Flow from IADS to TBFM .....	56
4.4	IADS RAMP USER INTERFACES.....	58
4.5	MOBILE APP/SHORT MESSAGE SERVICE (SMS) TEXTING .....	59
4.6	REAL-TIME DASHBOARD .....	61

<b>5</b>	<b>INTERFACE VIEW OF ATD-2</b> .....	<b>62</b>
5.1	NETWORK INFRASTRUCTURE.....	62
5.2	NASA AMES RESEARCH CENTER (ARC).....	63
5.3	NASA NORTH TEXAS RESEARCH STATION (NTX).....	63
5.4	WASHINGTON ARTCC (ZDC) AND ATLANTA ARTCC (ZTL).....	63
5.5	CHARLOTTE DOUGLAS INTERNATIONAL AIRPORT (CLT).....	64
5.6	FAA WILLIAM J HUGHES TECHNICAL CENTER (WJHTC).....	64
<b>6</b>	<b>SUMMARY</b> .....	<b>66</b>
<b>7</b>	<b>REFERENCES</b> .....	<b>67</b>
	<b>APPENDIX A: IADS OPERATIONAL ENVIRONMENT</b> .....	<b>69</b>
	<b>APPENDIX B: ATD-2 PROJECT FIELD DEMONSTRATION STRATEGY</b> .....	<b>71</b>
B.1	PHASE 1: BASELINE IADS .....	71
B.2	PHASE 2: FUSED IADS.....	72
B.3	PHASE 3: METROPLEX IADS.....	74
	<b>APPENDIX C: SURFACE DATA ELEMENTS</b> .....	<b>76</b>
C.1	ACTUAL OFF-BLOCK TIME (AOBT).....	76
C.2	ACTUAL TAKEOFF TIME (ATOT) .....	77
C.3	ACTUAL LANDING TIME (ALDT).....	77
C.4	ACTUAL IN-BLOCK TIME (AIBT).....	77
C.5	AIRCRAFT TAIL/REGISTRATION #.....	77
C.6	EARLIEST OFF-BLOCK TIME (EOBT).....	78
C.7	FLIGHT CANCELLATION.....	78
C.8	FLIGHT INTENT .....	78
C.9	GATE ASSIGNMENT .....	79
C.10	INITIAL OFF-BLOCK TIME (IOBT) .....	79
C.11	EARLIEST RUNWAY TIME OF DEPARTURE (ERTD).....	79
	<b>APPENDIX D: SECURITY, NEXUS, AND INTERFACES</b> .....	<b>81</b>
	<b>APPENDIX E: ACRONYMS</b> .....	<b>83</b>

## List of Figures

Figure 2.1 - NASA and FAA research and development activities have contributed significantly to ATD-2. ....	4
Figure 2.2 - The Decision Support Systems (DSS) programs are managed within the FAA Program Management Organization. ....	5
Figure 2.3 - Integrated Traffic Flow Management (TFM) systems work together to enhance the NAS [as briefed at April 2016 CDM meeting].....	6
Figure 2.4 - This general overview of the Traffic Flow Management System (TFMS) shows the primary functions of the system [as briefed at April 2016 CDM meeting]. ....	7
Figure 2.5 - Metering and sequencing with Time Based Flow Management (TBFM) provides significant advantages to stakeholders [as briefed at April 2016 CDM meeting]. ....	9
Figure 2.6 - The four components of Terminal Flight Data Manager (TFDM) include Electronic Flight Data, Surface CDM, Surface TFM and System Consolidation [as briefed at April 2016 CDM meeting]. ....	11
Figure 2.7 - The Electronic Flight Data (EFD) component of TFDM will replace paper strips in the Airport Traffic Control Towers, enabling data sharing with other NAS systems. ....	12
Figure 2.8 - The Surface CDM component of TFDM will implement a collaborative departure queue management solution. ....	13
Figure 2.9 - System Wide Information Management (SWIM) is being implemented in segments [as briefed to NASA in July 2016]. ....	15
Figure 2.10 - The Spot and Runway Departure Advisor (SARDA) computes pushback advisories to help ramp controllers meet target times in the ramp and movement area.....	16
Figure 2.11 - Precision Departure Release Capability (PDRC) uses information from a trajectory-based surface system to improve TBFM tactical departure scheduling.....	17
Figure 3.1 - The ATD-2 high level operational concept graphic (OV-1) shows the various user interfaces and system components.....	18
Figure 4.1 - This simplified view of the ATD-2 IADS architecture shows only the major components. ....	22
Figure 4.2 - The logical architecture for the IADS field demonstration system is shown to the next level of detail.....	23
Figure 4.3 - The ATD-2 STBO Block diagram is shown as it is implemented in Phase 1.....	24
Figure 4.4 – The ATD-2 Surface Modeler component consumes/produces a variety of data. ....	28
Figure 4.5 – High level design of the IADS scheduler .....	30
Figure 4.6 – The Surface Scheduler component consumes/produces a variety of data.....	34
Figure 4.7 - The SMP user interface component consumes/produces a variety of data. ....	38
Figure 4.8 - TFDM SWIM Engine .....	39
Figure 4.9 - This illustration shows the data flow to/from the Fuser.....	41
Figure 4.10 - The Fuser architecture overview shows the communication flow of the sub-components that comprise the Fuser system. ....	43
Figure 4.11 - The Airport Resource Management component consumes/produces a variety of data. ....	47
Figure 4.12 - Elements of STBO Client Interface. ....	50
Figure 4.13 - The Surface Situational Display component consumes/produces a variety of data.....	51
Figure 5.1 - This geographic depiction shows the locations of the NASA installations that will support the ATD-2 field demonstration. ....	62

Figure 5.2 – This figure highlights the interfaces between FAA and NASA information systems for the ATD-2 field demonstration. ....	65
---	----

## List of Appendix Figures

Figure A.1 - A simplified view of the ATD-2 project operational environment for the Phase 1 Baseline IADS Demonstration illustrates a variety of surface and airspace control points, plus impacts due to weather and downstream demand/capacity imbalances. ....	69
Figure B.1 - The ATD-2 project employs a field demonstration strategy built upon three distinct phases, each representing an increased system capability. ....	71
Figure B.2 - This operational overview of the IADS system highlights both the participants at various facilities and the system improvements for the Phase 1 Baseline IADS Demonstration. ....	72
Figure B.3 - This enhanced operational overview of the IADS system highlights both the participants at various facilities and the system improvements for the Phase 2 Fused IADS Demonstration. ....	73
Figure B.4 - ATD-2 Phase 2 capabilities summary. ....	74
Figure B.5 - This full operational overview of the IADS system highlights both the participants at various facilities and the system improvements for the Phase 3 Metroplex IADS Demonstration. ....	75
Figure C.1 – These 11 surface data elements will be provided via TFMS Release 13. <sup>15</sup> ....	76
Figure D.1 - NASA’s information system security plan uses the NextGen Emulation system (NEXUS) abstraction to define system boundaries and two classes of system interfaces. ....	81

## List of Tables

Table 4-1 Flight Status/States are necessary for taxi trajectory predictions and flight scheduling. ....	25
Table 4-2 - ATD-2 TTP Information Service Implementation ....	40
Table 4-3 - ATD-2 Fuser components are described in detail. ....	44
Table 4-4 - Fuser database processors record Fuser data to a PostgreSQL database. ....	45
Table 4-5 - Fuser core components fuse data into a common format. ....	45
Table 4-6 - Fuser STBO components serve as an interface between STBO and the Fuser system. ....	46
Table 4-7 - Flight TMI Service - TMI Types and Sources ....	52

# 1 Introduction

## 1.1 Identification

This Technology Description Document (TDD) provides an overview of the technology for the Phase 1 Baseline and Phase 2 Fused demonstrations of the Integrated Arrival, Departure, and Surface (IADS) prototype system of the National Aeronautics and Space Administration's (NASA) Airspace Technology Demonstration 2 (ATD-2) project, which has been demonstrated since October of 2017 at Charlotte Douglas International Airport (CLT). Development, integration, and field demonstration of relevant technologies of the IADS system directly address recommendations made by the Next Generation Air Transportation System (NextGen) Integration Working Group (NIWG) on Surface and Data Sharing and the Surface Collaborative Decision Making (Surface CDM) concept of operations developed jointly by the Federal Aviation Administration (FAA) and aviation industry partners. NASA has been developing the IADS traffic management system under the ATD-2 project in coordination with the FAA, flight operators, CLT airport operators, and the National Air Traffic Controllers Association (NATCA). The primary goal of ATD-2 is to improve the predictability and operational efficiency of the air traffic system in metroplex environments, through the enhancement, development, and integration of the nation's most advanced and sophisticated arrival, departure, and surface prediction, scheduling, and management systems.

The ATD-2 project is a 5-year research activity beginning in 2015 and extending through 2020. The Phase 1 Baseline IADS capability resulting from the ATD-2 research has been demonstrated at the CLT airport since the beginning of October 2017. Phase 1 provided data exchange and integration with the initial demonstration of the integrated system of strategic and tactical scheduling, collaborative tactical surface metering, tactical departure scheduling to an en route meter point and overhead stream insertion, initial integration of a TFDM SWIM prototype feed, and an early implementation prototype of a Terminal Flight Data Manager (TFDM) Electronic Flight Data (EFD) system. The strategic surface scheduling element of the capability is consistent with the Surface CDM Concept of Operations published in 2014 by the FAA Surface Operations Directorate.<sup>1</sup>

The Phase 2 Fused IADS system provided substantial updates to baseline IADS Demonstration capability. Improvements were made to the IADS modeler; tactical surface scheduling, and metering; tactical departure scheduling for overhead stream insertion; Electronic Flight Data (EFD) and the integration with the FAA Advanced Electronic Flight Strip (AEFS); RTC/RMTC, and departure trajectories. New capabilities included a TFDM SWIM prototype feed and delivery of IADS data via the TFDM Terminal Publication (TTP) service of the FAA's SWIM system; strategic surface scheduling and metering as well as fusion with tactical surface metering; integration and ingestion of data from TTP-connected Mobile App and texting industry for General Aviation (GA) flights; and expansion of airspace deployments to include adjacent Center automation, in particular interface with the Atlanta Center (ZTL) arrival metering TBFM system to evaluate pre-scheduling of flights. Improvements in Data Analysis and System Health (DASH) monitoring and updates were completed as well.

## **1.2 Background**

This TDD is intended to be a companion document for the ATD-2 Concept of Use (ConUse) document.<sup>2</sup> The reader will be referred to the ConUse document for sections where the inclusion of that material in the TDD would be repetitive. Please consult Section 1.2 of the Phase 1 ConUse<sup>2</sup> for background on the ATD-2 subproject.

## **1.3 Document Purpose and Scope**

The primary purpose of the ATD-2 TDD is to support the ConUse by providing a moderate-level overview of the technology comprising the IADS traffic management system. Implementation details provided herein are generally outside the scope of the ConUse, but will likely provide helpful context to the readers of the ConUse.<sup>2</sup>

This document may also prove useful to ATD-2 team members, research partners, and stakeholders who desire a better understanding of the IADS system architecture and implementation strategy. The reader should note that this TDD is not intended to be a formal system design document. Rather it is an overview of the technologies that contribute to the IADS system, and describes how they are being integrated to support the field demonstration and evaluation.

The ATD-2 field demonstration is divided into three phases, as described in Appendix B. At the end of each demonstration phase, NASA will provide an ATD-2 technology transfer to the FAA and industry partners.

System capability will increase from one phase to the next. The original ConUse document was limited to Phase 1 in order to clearly identify just those system capabilities required for Phase 1 success. The Phase 2 ConUse was then created as an addendum to the Phase 1 ConUse. The ConUse will again be updated for Phase 3 prior to the operational evaluation freeze point for that phase. The Phase 1 system forms the foundation for Phase 2 and Phase 3. Consequently, the system design must look ahead to the future phases, but this document will contain more detail for system components required for the Phase 1 and Phase 2 deployment and demonstration.

The intended audience for this document includes:

The NASA ATD-2 team, who will use this document to coordinate research and development activity with NASA and its research partners, including the FAA, flight operators, the CLT airport operators, and the Surface CDM community.

The NASA/FAA IADS Research Transition Team (RTT), which is facilitating the research transition process.

The FAA NextGen implementers, who may use this TDD and other ATD-2 research products, to inform development of the IADS elements of the NextGen enterprise architecture.

## **1.4 Document Organization**

This document is organized as follows:

Section 1 provides introductory and background material and describes the nature of this document.

Section 2 describes the various FAA and NASA technologies that contribute to the ATD-2 IADS system.

Section 3 presents an operational view of IADS, with reference to the technologies in use at each operational location.

Section 4 presents a system view of ATD-2 IADS via the logical architecture diagram and subsystem descriptions.

Section 5 presents an interface view of ATD-2 IADS, with reference to external data interfaces.

Section 6 contains the document summary.

Section 7 contains references cited and documents consulted.

Appendix A describes the operational environment for IADS.

Appendix B contains a high-level description of the three phases of ATD-2 technology demonstrations.

Appendix C describes the surface data elements.

Appendix D provides background information on security, NEXUS, and interfaces.

Appendix E contains acronyms in common use within the ATD-2 project.

## 2 Technologies Contributing to ATD-2

The ATD-2 IADS traffic management system is being built on a rich legacy of NASA, FAA, and industry research and technology development. Figure 2.1 illustrates the relationships among the various contributing technologies. The timescale for this chart was chosen to capture key technology transfers (small yellow arrows) contributing to ATD-2, which is depicted by the blue arrow beginning in 2014. Many of the Research and Technology (R&T) activities began before 2010, and ATD-2 will continue through 2020 with technology transfers to the FAA, flight operators, airport operators, and suppliers beginning in 2018. The two yellow stars on the ATD-2 timeline highlight the ATD-2 initial deployment and the Phase 1 field demo go-live in CLT.

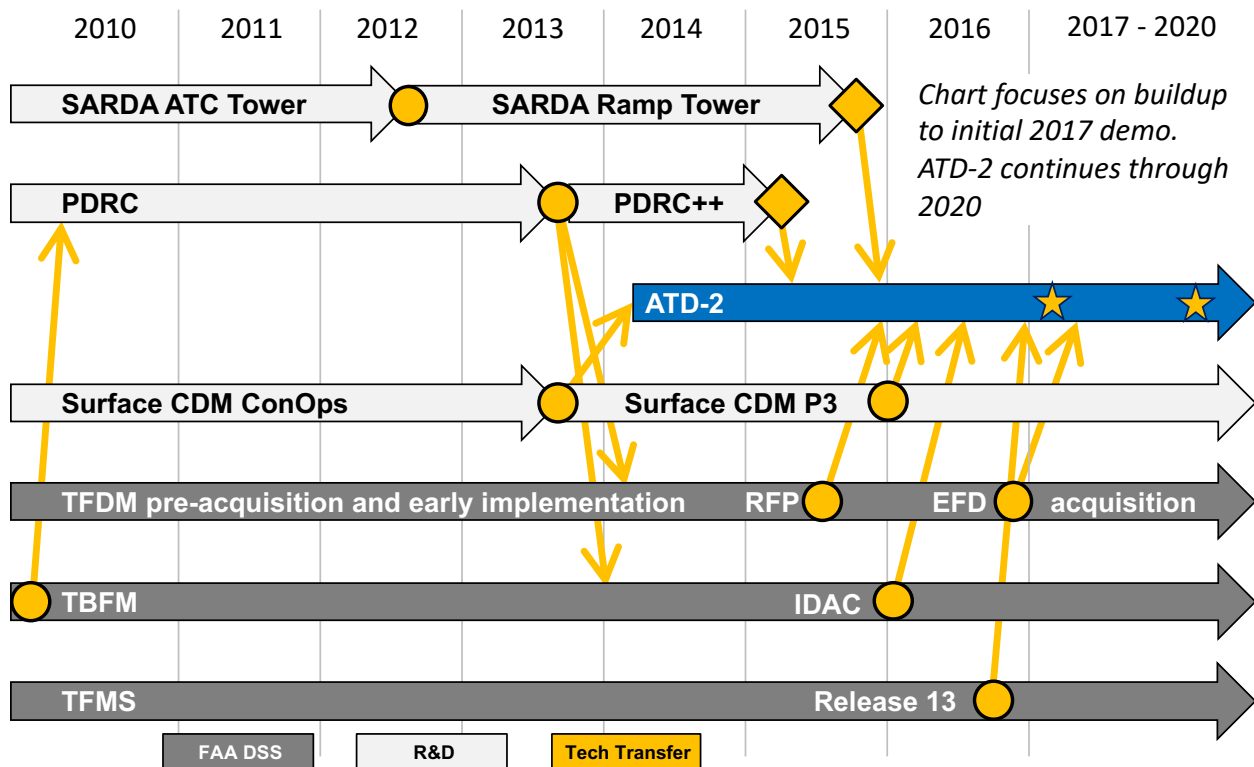

Figure 2.1 - NASA and FAA research and development activities have contributed significantly to ATD-2.

The remainder of this section will provide a brief overview of the various technologies depicted in Figure 2.1. The narrative will periodically reference Figure 2.1 to help connect each technology to its role in the IADS prototype system.

### 2.1 FAA Contributing Technologies

The three dark grey arrows at the bottom of Figure 2.1 represent the FAA’s NextGen Air Traffic Management (ATM) Decision Support Systems (DSS)<sup>3</sup> that provide most of the IADS capabilities in the National Airspace System (NAS). The three DSS programs all begin with the letter “T” and are commonly called the “3Ts.” As shown in Figure 2.2, the 3Ts are managed together within the FAA’s Program Management Organization.

The following is an excerpt from the FAA’s NextGen website:<sup>3</sup>



Decision Support Systems (DSS) optimize traffic flow across the National Airspace System (NAS). They integrate multiple technologies and suggest faster, more effective responses to evolving conditions. They share data among air traffic controllers, traffic managers, and other stakeholders who develop collaborative solutions for traffic flow constraints...

Three "Ts" comprise DSS. They are the Traffic Flow Management System (TFMS), Time Based Flow Management (TBFM), and the Terminal Flight Data Manager (TFDM). Each component has a specific role, but working together they provide integrated, responsive, and collaborative traffic flow management solutions that maximize efficiency and reduce delays through each phase of flight.

This section gives a top-level description of the FAA suite of decision support Traffic Flow Management (TFM) tools – the 3T systems of TFMS, TBFM, and TFDM. These tools are designed to enhance the NAS by ensuring an efficient flow of traffic and maintaining throughput while improving situational awareness through real-time information sharing and improving the quality of service to NAS users by accommodating user preferences.

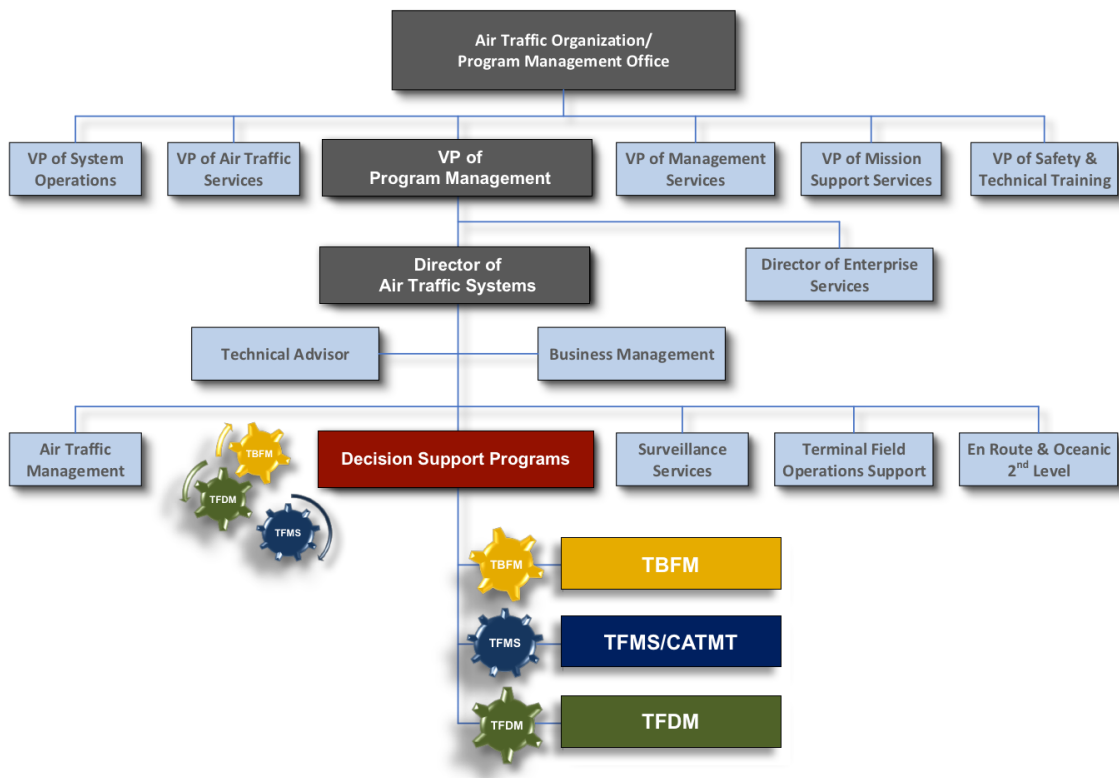

Figure 2.2 - The Decision Support Systems (DSS) programs are managed within the FAA Program Management Organization.

The goal of these tools is to provide integrated, responsive, and collaborative air traffic control solutions that maximize efficiency and reduce delay. Integration is achieved by modeling and implementing strategic and tactical Air Traffic Control (ATC) strategies as a single cohesive strategy. An emphasis on responsiveness promotes more effective responses to evolving conditions in the NAS. By facilitating solutions that impose minimal controls on flights, data sharing among stakeholders enhances collaboration and thus allows flight operators to fly their preferred routes at preferred times.

Figure 2.3 shows the conceptual view of TFM as it is applied across the various stages of flight, implemented for both strategic and tactical operations, and used by the various air traffic control facilities.

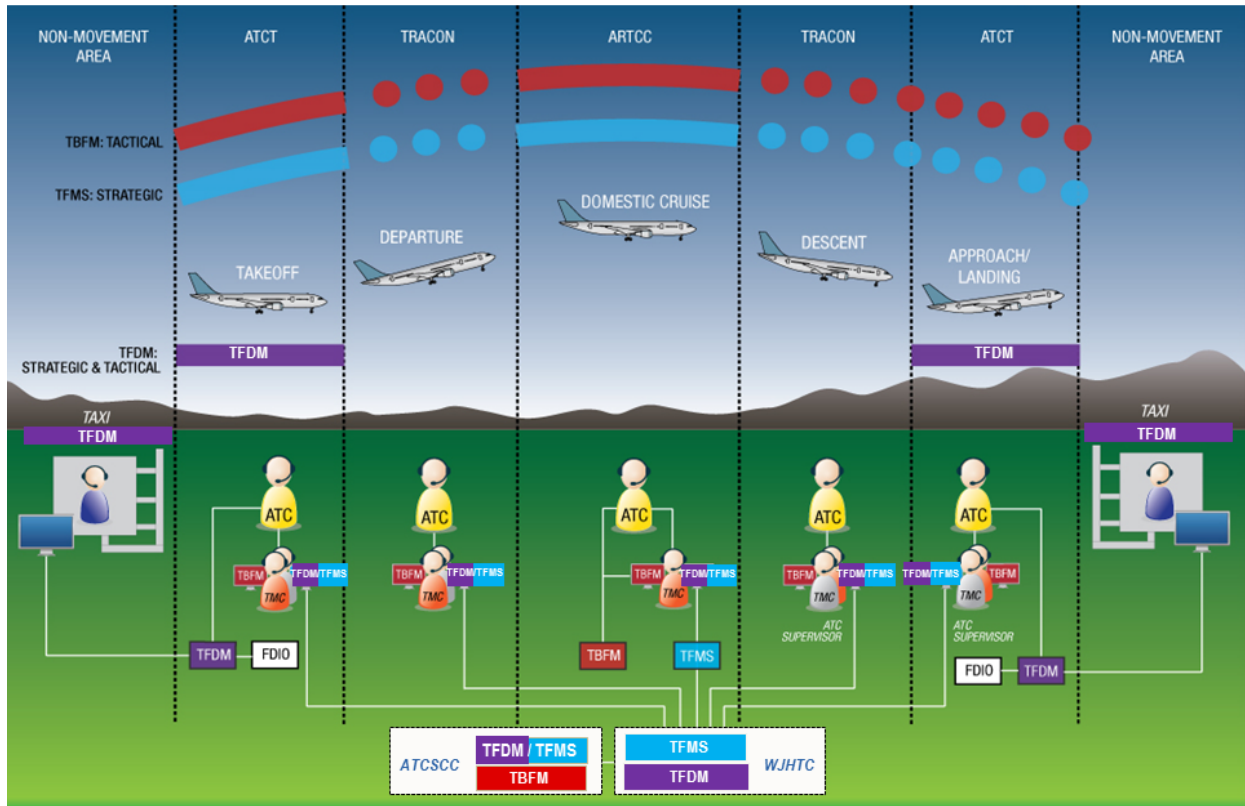

Figure 2.3 - Integrated Traffic Flow Management (TFM) systems work together to enhance the NAS [as briefed at April 2016 CDM meeting].

Integration of the 3T systems is a major emphasis for the FAA, and it is central to the ATD-2 concept and field demonstration effort.

### 2.1.1 Traffic Flow Management System (TFMS)

The following is an excerpt from the FAA's NextGen website:<sup>3</sup>

TFMS is a suite of automation tools that serves as the FAA's primary system for planning and implementing traffic management initiatives (TMI) that mitigate demand and capacity imbalances throughout the NAS. TFMS is tactical when applied locally and strategic when being used to balance capacity throughout the whole system.

TFMS monitors demand and capacity information, assesses the impact of system constraints, provides alerts, and helps determine appropriate adjustments. Benefits include increased predictability, flexibility, efficiency, and capacity, as well as decreased delays, uncertainty, safety risks, and costs to all participants.

The TFMS is a decision support system for planning and mitigating demand/capacity imbalances in the NAS. Its main objective is to efficiently improve the overall NAS by monitoring the NAS, predicting demand/capacity imbalances, and balancing demand with capacity, as shown in Figure 2.4. TFMS is relevant in scope for both the national and regional areas of the NAS.

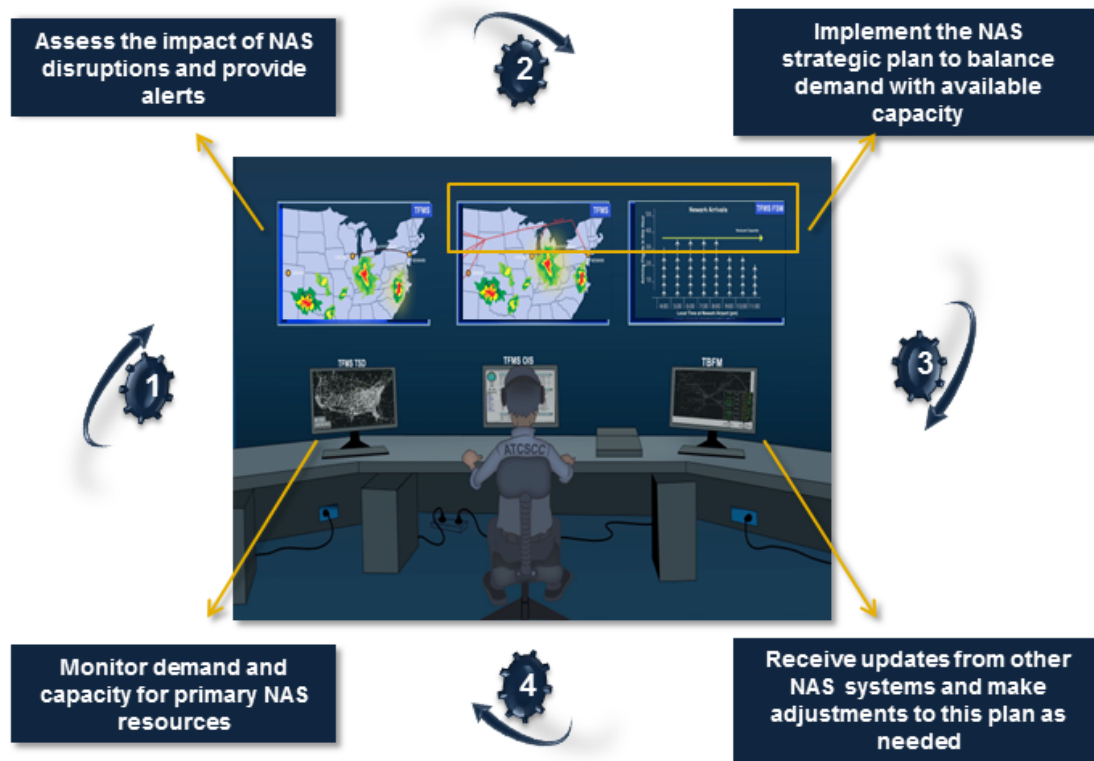

Figure 2.4 - This general overview of the Traffic Flow Management System (TFMS) shows the primary functions of the system [as briefed at April 2016 CDM meeting].

TFMS has a strategic planning horizon of up to 12 hours, and a tactical planning horizon of up to 90 min. The main operational users of TFMS are the Command Center’s TFMs, the Air Route Traffic Control Center (ARTCC, or Center) Traffic Management Unit (TMU), Traffic Management Coordinators (TMCs), the airport TMU TMC/Supervisor, and non-FAA NAS users. The TMI control mechanisms that this system uses are to delay flights on the ground and to reroute flights to less congested areas.

As illustrated by the yellow technology transfer arrow in Figure 2.1, the ATD-2 IADS system utilizes TFMS Release 13 (R13), which was deployed on 30 April 2016. R13 provides the mechanism for flight operators and the FAA to exchange the surface data elements specified in the Surface CDM Concept of Operations (ConOps).<sup>1</sup> The FAA’s NextGen website<sup>3</sup> provides the following background on R13 data sharing:

The FAA is committed to ensuring its Decision Support Systems can access the most current and accurate information. As part of a two-way data sharing agreement brokered through the NextGen Advisory Committee (NAC), a public-private federal advisory group, air carriers have begun to provide the FAA with additional operational

information. The information is entered into TFMS and will be disseminated to other systems through System Wide Information Management (SWIM).

This information will mark the times of aircraft "events" that occur on the ground. These events include the earliest time the aircraft can leave the gate, the time it enters the taxiway, and the time it reaches the runway, ready for takeoff. The FAA, in turn, will use this data to improve efficiency.

The NAC-brokered agreement mentioned in the preceding excerpt includes a commitment by the FAA to use the surface data elements provided by flight operators to implement departure queue management consistent with the Surface CDM ConOps.<sup>1</sup> This was one of the primary motivators for FAA/NASA collaboration on the ATD-2 field demonstration and its deployment of Surface Metering Program (SMP), which has reduced the risk for the TFDM implementation of the Surface CDM departure queue management.

Basic surface data elements in R13 include: actual off-block time (AOBT), actual takeoff time (ATOT), actual landing time (ALDT), actual in-block time (AIBT), aircraft tail/registration number, earliest off-block time (EOBT), flight cancellation message, flight intent (e.g., whether the flight operator plans to pushback early during a Surface Metering Program (SMP) and hold in the movement area), gate assignment, initial off-block time (IOBT), and earliest runway time of departure (ERTD). More information on these data elements is provided in Appendix C.

### ***2.1.2 Time Based Flow Management (TBFM)***

The following is an excerpt from the FAA's NextGen website:<sup>3</sup>

TBFM uses time instead of distance to help controllers sequence air traffic. Compared to the traditional miles-in-trail process, TBFM provides a more efficient traffic flow that reduces fuel burn and increases traffic capacity.

TBFM uses the capabilities of the Traffic Management Advisor (TMA), a system already deployed to all en route centers — the facilities that control air traffic between the termination point of a departure procedure and the origination point of an arrival procedure. Improvements in TMA's trajectory modeler and time-based metering, which regulate traffic flow by directing aircraft to be at a specific location at a specific time, optimize arrival flow. TBFM enables en route controllers to deliver aircraft more accurately to controllers in the Terminal Radar Approach Control (TRACON) facility...

TBFM metering creates a time slot for specific fixed points along an aircraft's route. Controllers use speed advisories or vectors to direct an aircraft to cross the fixed point at the allotted time. Extended metering increases the distance from the airport where metering is conducted without significant degradation in the accuracy of aircraft times at the meter reference points. Controllers can deconflict flow for metered aircraft at the reference points and meter fixed points.

TBFM is a decision support system for metering based on time to optimize the flow of aircraft. Its main objectives are the sequencing and spacing of airborne flights, merging of departures into the overhead stream, and maximizing the use of flow capacity, as shown in Figure 2.5.

TBFM is relevant in scope for 300 NM from a metering location. It has a tactical planning horizon of up to 90 minutes. The main operational users of TBFM are the Command Center's TFM's and the Center TMCs, the TRACON TMCs, and the airport TMCs that each reside in that facility's TMU. The TMI control mechanisms that this system uses are time-based metering and delaying flights on the ground.

After TFMS implements a NAS strategy, TBFM meters and sequences the flow of aircraft through congested areas to provide a smooth and orderly flow. TBFM metering lists are generated using complex algorithms, which consider many factors (e.g., aircraft type, wind predictions) to maximize use of the available capacity. They are updated dynamically as conditions change. TBFM assists Air Traffic Controllers by displaying the required delay for each aircraft in the metering list.

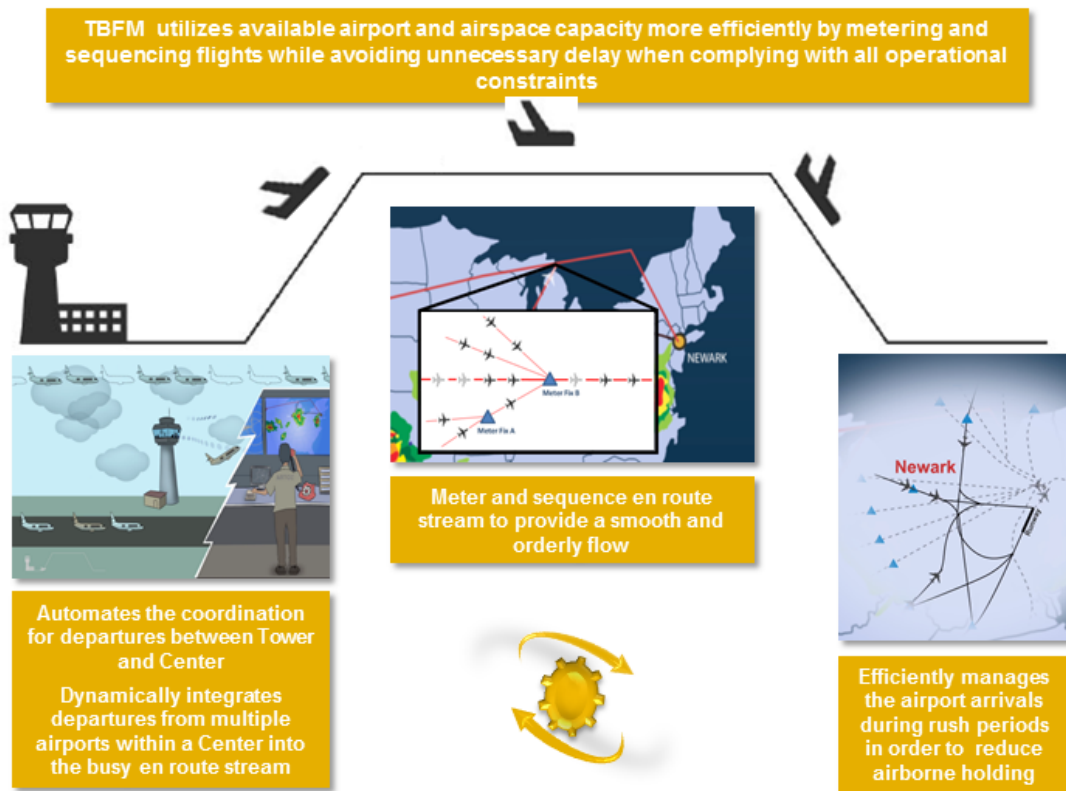

Figure 2.5 - Metering and sequencing with Time Based Flow Management (TBFM) provides significant advantages to stakeholders [as briefed at April 2016 CDM meeting].

Figure 2.1 shows three yellow technology transfer arrows associated with TBFM. The first arrow on the far left denotes the fact that the en route portion of NASA’s Precision Departure Release Capability (PDRC)<sup>4</sup> was created from the operational TBFM software. At the conclusion of PDRC, a technology transfer package was delivered to the TBFM and TFDM programs to serve as a guide for en route/surface integration. The arrow on the far right denotes the fact that ATD-2 will leverage the latest FAA investments in TBFM called Integrated Departure Arrival Capability (IDAC). IDAC is described on the DSS website<sup>3</sup> as follows:

Integrated Departure Arrival Capability (IDAC) automates the process of monitoring departure demand and identifying departure slots. IDAC coordinates the departure times between airports and provides situational awareness to air traffic control towers so they can select from available departure times and plan their operations to meet these times...

An enhancement to IDAC introduces a new tower-focused user interface called the Integrated Departure Scheduling Tool (I). It streamlines departure scheduling in

automatic and semi-automatic modes. It improves situational awareness of current and future congestion over constrained areas. It automates notification of new constraints and approval request status. It enables more accurate and efficient traffic flow.

TBFM/IDAC provides a solid foundation for the tactical departure scheduling functions of the IADS system.

### ***2.1.3 Terminal Flight Data Manager (TFDM)***

The following is an excerpt from the FAA's NextGen website:<sup>3</sup>

Some of the best opportunities to improve the efficiency of air traffic reside on the ground and in the terminal. The FAA is developing the Terminal Flight Data Manager (TFDM) to take advantage of those opportunities. TFDM enables efficiencies in airport surface operations and in the terminal airspace. It operates through four core functions:

- Electronic flight data distribution
- Traffic flow management
- Collaborative decision-making on the airport surface
- Systems consolidation

The FAA awarded a contract to Lockheed Martin in July 2016 to develop and implement TFDM. Key sites will become operational most likely by mid 2021.

TFDM is a decision support system for airport surface management and Airport Traffic Control Towers (ATCT, or Tower) functions. Its main objectives are to improve Tower controller efficiency for Tower operations, to manage flights on the airport surface, and to improve the efficiency of surface operations. TFDM is relevant in scope for the airport surface (i.e., gate/ramp, taxiway, and runway).

TFDM has a strategic planning horizon of up to 4 hours, and a tactical planning horizon of up to 60 minutes.<sup>5</sup> The main operational users of TFDM are the airport Tower controllers, the airport TMU/TMC/Supervisor, and non-FAA NAS users. The TMI control mechanism that this system uses is holding of flights at the gate.

TFDM is an acquisition program with four envisioned components that include Electronic Flight Data (EFD), Surface CDM, Surface TFM, and System Consolidation, shown in Figure 2.6. The Surface CDM component includes Departure Reservoir Queue Management (known as DRM), for which ATD-2 is substituting it with Surface Metering Program (SMP). The System Consolidation component will replace or incorporate several system pieces, including the Advanced Electronic Flight Strip (AEFS) Prototype System, the Departure Sequencing Program (DSP), the Electronic Flight Strip Transfer System (EFSTS), the Surface Movement Advisor (SMA), and the Airport Resource Management Tool (ARMT). The ARMT is a tool used by Front Line Managers (FLM) and/or TMCs to provide the ability to monitor and analyze arrival and departure demand, based on flight plan and event data received from the TRACON and flight event data received from the Tower. This tool is being transitioned out as TFDM comes into play.

The TFDM program successfully passed the Final Investment Decision (FID) milestone on 15 June 2016, and the TFDM acquisition contract award was publicly announced on 7 July 2016. It has gone through the development phase, has achieved various milestones and it is striving towards its deployments by 2021.

The yellow technology transfer arrow connecting TFDM to ATD-2 in Figure 2.1 denotes the central role that TFDM system requirements have played in the development of ATD-2 IADS. The ATD-2 team carefully studied the TFDM Screening Information Request (SIR)<sup>6</sup> package to ensure that the ATD-2 IADS system architecture and requirements were well aligned with the

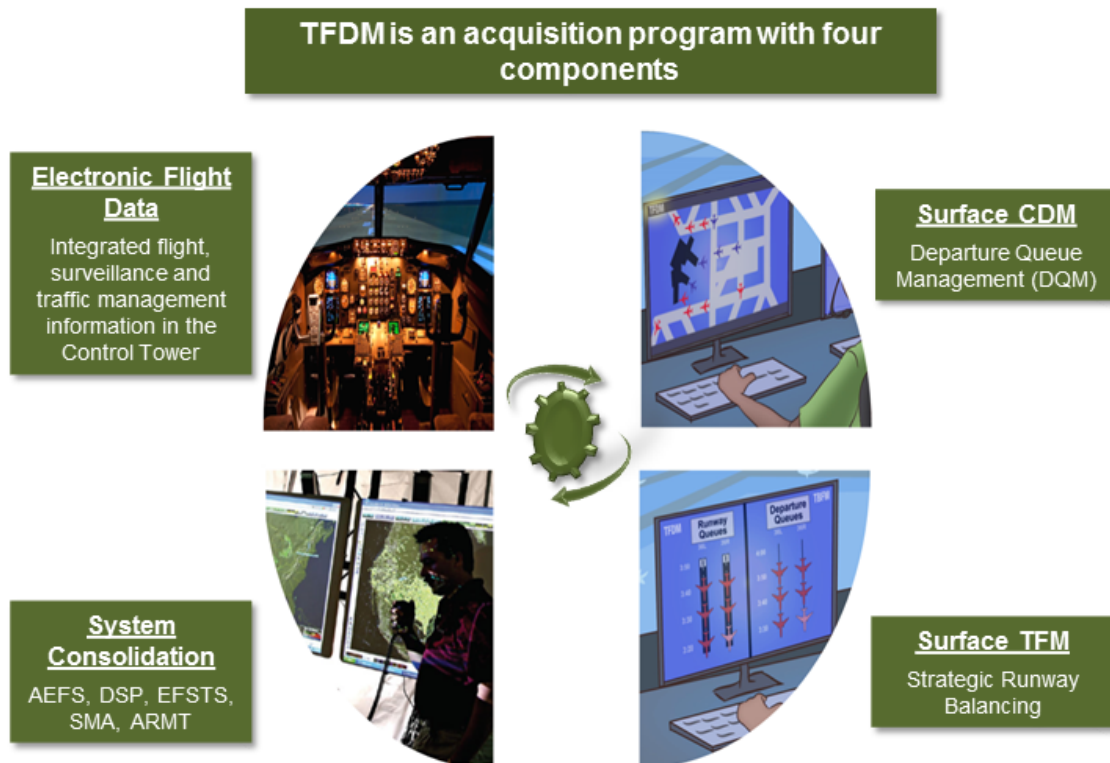

Figure 2.6 - The four components of Terminal Flight Data Manager (TFDM) include Electronic Flight Data, Surface CDM, Surface TFM and System Consolidation [as briefed at April 2016 CDM meeting].

FAA plans. The motivation for doing so was to maximize the benefit to our FAA and industry partners, and to minimize the barriers to technology transfer.

The EFD and Surface CDM components of the TFDM program are particularly relevant to ATD-2, and are further described in the following subsections.

### 2.1.3.1 Electronic Flight Data (EFD)

The following is an excerpt from the FAA's TFDM website:<sup>7</sup>

TFDM provides air traffic controllers with a view of available surface and terminal area surveillance information when integrated with electronic flight data information. The EFD exchange replaces paper flight strips with electronic processing and distribution of Instrument Flight Rules and Visual Flight Rules data. Automated manual flight data processes enable enhanced data sharing between air traffic, traffic management, and Flight/Airline Operators, and other aviation stakeholders. The TFDM system will replace the Electronic Flight Strip Transfer System (EFSTS) in the tower and Terminal Radar Approach Control Facilities (TRACON), and the Advanced Electronic Flight Strip (AEFS) Prototype System in the towers.



Figure 2.7 includes a typical screenshot of the AEFS ground controller user interface. The FAA deployed the AEFS prototype system to a number of Airport Traffic Control Towers (ATCTs) as part of the TFDM early implementation effort designed to address immediate needs for the EFD capability of TFDM.

The screenshot displays the AEFS ground controller user interface. It features a top menu bar with options like 'All', 'None', 'Multiple', 'Move', 'New FS', 'Memo', 'FDIO', 'CD', 'GM', 'GC', 'LC', 'AM', 'TM', and 'Discard'. Below the menu is a grid of flight data tables. Each table has columns for 'PU', 'PD', 'Total', 'Set', and 'Imp'. The tables contain flight information such as flight numbers (e.g., J2A7979, CRJ29Q, CAP3205), altitudes, and other operational details. The interface also includes various control buttons and a 'Command' field.

Figure 2.7 - The Electronic Flight Data (EFD) component of TFDM will replace paper strips in the Airport Traffic Control Towers, enabling data sharing with other NAS systems.

To support ATD-2, the FAA committed to deploy a TFDM EFD solution to CLT ATCT prior to the beginning of the Phase 1 field demonstration. The FAA determined that AEFS would be the interim solution for EFD for the ATD-2 Phase 1 demo. Per this plan, the FAA provided the AEFS software to NASA, and AEFS training systems were installed at the NASA Ames Research Center (ARC) and the NASA/FAA North Texas Research Station (NTX) facilities. The FAA implemented AEFS at the CLT tower in June 2017, and AEFS has been in continuous operational use at CLT since that time.

### 2.1.3.2 Surface Collaborative Decision Making (Surface CDM)

The following is an excerpt from the FAA's TFDM website:<sup>7</sup>

TFDM provides surface Collaborative Decision Making (CDM) to support Departure Reservoir Management (DRM) for surface metering and demand information displayed at Air Traffic Control Towers (ATCTs), Terminal Radar Approach Control (TRACONS) facilities, Air Route Traffic Control Centers (ARTCCs), and the Air Traffic Control System Command Center (ATCSCC). Surface CDM is the sharing of flight movement and related operational information among Airport Operators, Flight Operators, Flight Service Providers, and FAA Stakeholders and improves demand and capacity predictions. It maximizes the use of available airport and airspace capacity, while minimizing adverse effects on Stakeholders, passengers, and the environment.



Referring again to Figure 2.1, the light grey arrow immediately below the ATD-2 arrow represents the FAA/industry Surface CDM effort that involved the FAA Surface Office, the Surface CDM Team, and other stakeholders. Figure 2.8 presents their building-block vision for extending CDM principles to the surface domain. The foundation is the two-way data sharing described in the excerpt above and realized with TFMS Release 13 (R13). This foundation supports the Surface CDM Ration by Schedule (RBS) departure metering solution known as DRM, which can then be linked to the rest of the NAS via the 3T integration effort described above. However, it appears that DRM has fallen out of favor, and as a result of NASA’s research work, the ATD-2 IADS system has replaced DRM with its Surface Metering Program (SMP) and has been able to demonstrate its capabilities at CLT (as part of the Phase 1 and Phase 2 deployment at that airport).

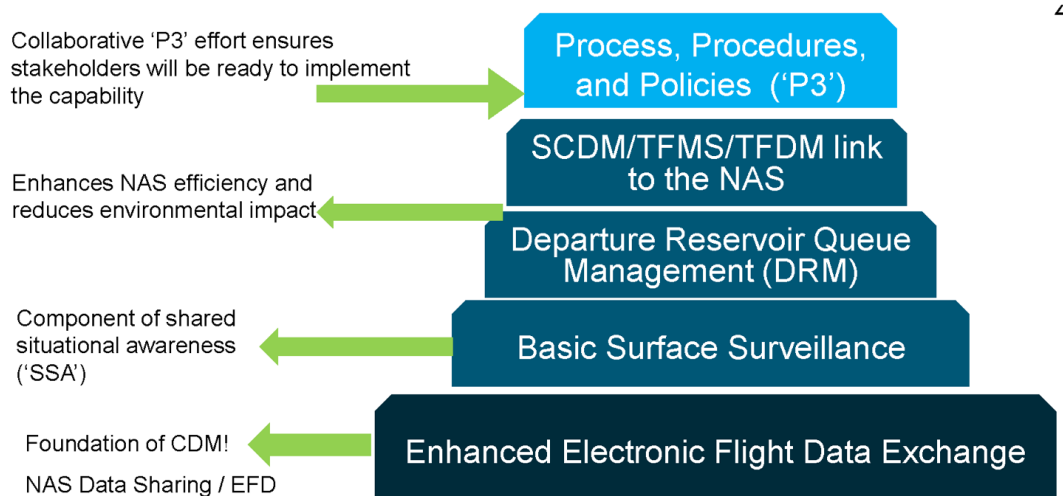

Figure 2.8 - The Surface CDM component of TFDM will implement a collaborative departure queue management solution.

The FAA Surface CDM concept engineering effort utilized a series of eight Human-in-the-Loop (HITL) exercises conducted between June 2012 and February 2013 to mature the Surface CDM Concept of Operations (ConOps). The ConOps was completed in July 2013 with formal publication in June 2014,<sup>1</sup> after endorsement by the CDM Stakeholders Group. The Surface CDM ConOps was incorporated into the TFDM ConOps published in Sep 2013. Following completion of the concept engineering effort, the FAA Surface Office led a group of stakeholders (Surface CDM Team and others) through a series of Process, Procedures and Policies (P3) exercises to identify P3 changes needed for effective implementation of the Surface CDM ConOps.

In May 2015, the FAA and NASA initiated a technology transfer effort to ensure that the ATD-2 project fully leveraged all of the FAA and industry investments in the Surface CDM effort. The technology transfer included reports, briefing packages, storyboards, workshop minutes, documentation, and the software used for the HITL exercises. To ensure a successful technology transfer, the Surface CDM HITL development contractor (Metron Aviation) was tasked to work with the ATD-2 team to implement the software in NASA’s development environment and integrate it with the ATD-2 IADS system. The DRM software delivered to NASA via this technology transfer forms the basis for the IADS strategic surface scheduler that later was integrated with the tactical scheduler to form what is known as the surface scheduler and its associated metering program.

### 2.1.4 System Wide Information Management (SWIM)

Although not one of the 3Ts, SWIM is included in this section because it is the essential “glue” that enables communication among the 3Ts and with external customers, seen in Figure 2.9. The following is an excerpt from the FAA’s NextGen website:<sup>3</sup>

System Wide Information Management (SWIM) provides the digital data-sharing backbone of NextGen. The information-sharing platform enables increased common situational awareness throughout the National Airspace System (NAS). It improves the FAA's ability to deliver the right information to the right people at the right time. The vision for SWIM is to transform the NAS into an agile, information-centric system by establishing common processes and infrastructure needed for NextGen.

SWIM relies on a standard data format so information from unrelated computer systems may be shared efficiently. It connects different producers and users of data with a common language and single point of contact...

SWIM is being implemented in segments. In each segment, a set of NAS services is being developed and integrated via SWIM. Segment 1 was completed in 2015. Segment 2a was completed in 2016. The SWIM program has deployed additional hardware to support the implementation of capabilities associated with the segments. SWIM enables systems to request and receive information when they need it, subscribe for automatic receipt, and publish information as appropriate.

Figure 2.9 shows various SWIM services grouped by implementation segment. NASA has “on-ramped” as a consumer to the various SWIM services such as the SWIM Terminal Data Distribution System (STDDS), the TFMS TFMDData service, the SWIM Flight Data Publication Service (SFDPS), and the SWIM TBFM service. In addition to being a consumer of the SWIM services, ATD-2 IADS is planning to become a SWIM producer to deliver data to field demonstration partners.

SWIM is providing the Service Oriented Architecture (SOA) for all NAS and Non-NAS consumers of the data. The TFD, TBFM, and TFMS programs are developing their SWIM Services. This means the data (from these systems) will be made available as a request/response by the user or system requesting that specific data. SWIM provides the capability of receiving data from multiple airports and multiple sources.

The SWIM Publishing environment works accordingly:

Systems publish data sets to SWIM Queues

SWIM Network Enterprise Messaging System (NEMS) nodes across FAA SWIM network use Consumer data requests and filtering rules to move data from SWIM Publish Queues to Consumer SWIM Topics

SWIM:

Replaces varied interfaces with modern standards-based data exchange

Provides SWIM Consumers access to info without directly connecting to individual systems

Facilitates leveraging a single interface to receive multiple data products

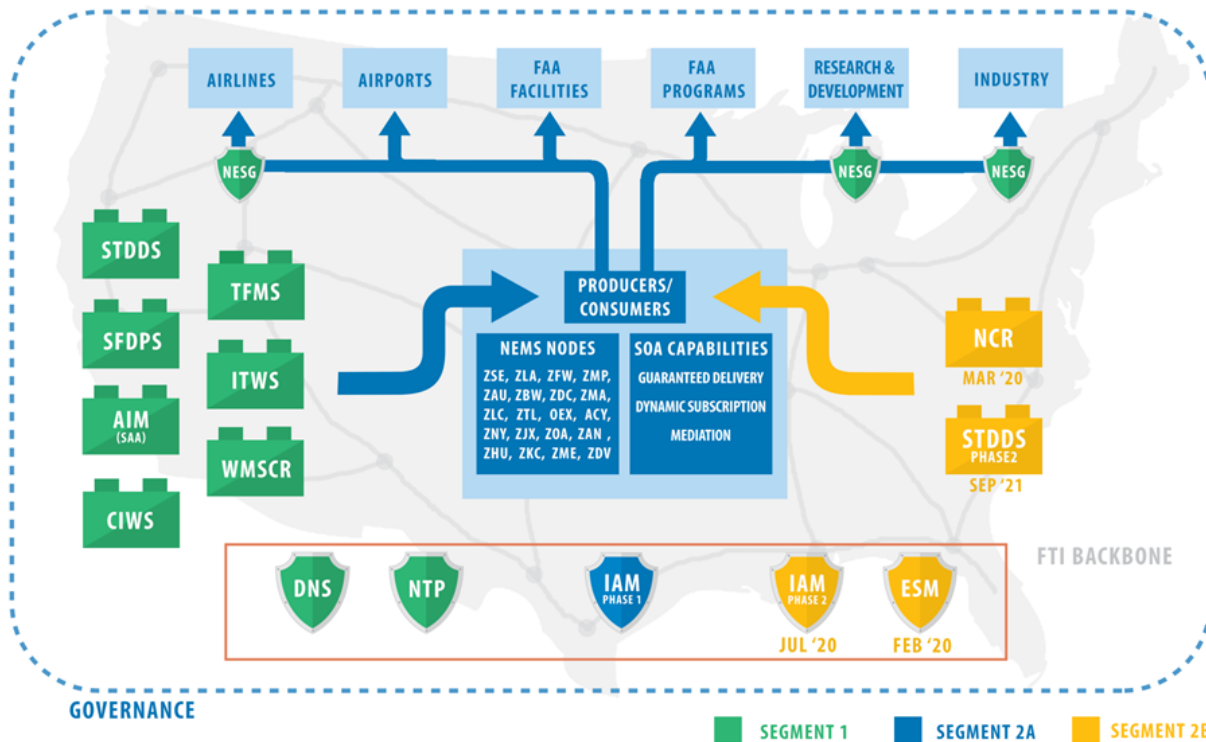

Figure 2.9 - System Wide Information Management (SWIM) is being implemented in segments [as briefed to NASA in July 2016].

Provides enterprise security for incoming and outgoing data

More information provided at: [www.faa.gov/nextgen/swim](http://www.faa.gov/nextgen/swim)

The SWIM data feed connection to the ATD-2 system, as well as the collection, integration, processing, distribution and display of the data, has been structured by using FAA Solace Repeater and Apache “ActiveMQ”, an open source, messaging broker software written in Java together with a full Java Message Service (JMS) client serving as a backbone for publishing and subscribing distributed data from more than one client or server.

## 2.2 NASA Contributing Technologies

The top two, light grey horizontal arrows in Figure 2.1 represent recent NASA research activities in the IADS domain (i.e., Spot and Runway Departure Advisor (SARDA) and Precision Departure Release Capability (PDRC)). The SARDA and PDRC concepts have been leveraged for ATD-2 IADS and some of their adopted functionality redistributed within the IADS architecture. The following two sections describe the Research and Development (R&D) work for these surface concepts and their history.

### 2.2.1 Spot and Runway Departure Advisor (SARDA)

The Spot and Runway Departure Advisor (SARDA)<sup>8</sup> uses trajectory-based surface predictions and advanced scheduling algorithms to provide departure metering advisories to controllers. Figure 2.10 shows the SARDA concept graphic and provides a high-level summary of the research activity.

As indicated in Figure 2.1, early SARDA research focused on movement area advisories for ATCT personnel. More recently, SARDA research focused on non-movement area (i.e., ramp) advisories for ramp controllers. The ramp-oriented portion of the SARDA research activity was accomplished in collaboration with US Airways, which later merged with American Airlines (AAL). The environment chosen for this collaborative research activity was the US Airways CLT hub. The research activity included a series of HITL experiments in NASA’s high-fidelity Future Flight Central (FFC) simulation facility. NASA’s SARDA team and their American Airlines partners were working towards a field evaluation of the SARDA technology at CLT when the research activity was folded into the larger ATD-2 field demonstration.

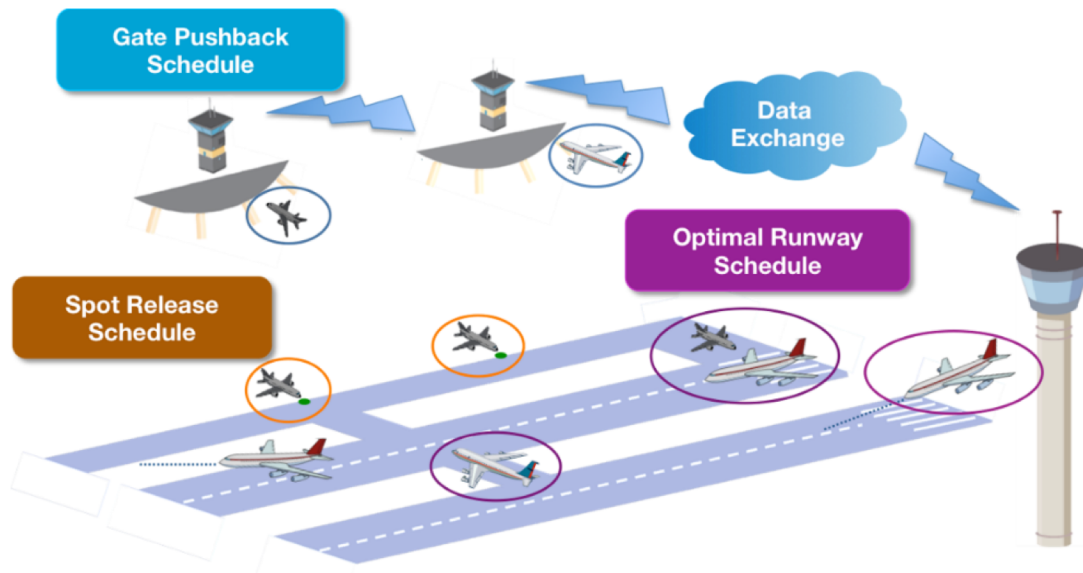

Figure 2.10 - The Spot and Runway Departure Advisor (SARDA) computes pushback advisories to help ramp controllers meet target times in the ramp and movement area.

ATD-2 has leveraged the SARDA concept for a tactical scheduler that provides pushback advisories to help ramp controllers in the CLT AAL Ramp Tower meet target times in the ramp and movement areas. ATD-2 has also incorporated the Ramp Traffic Console (RTC) and Ramp Manager Traffic Console (RMTC) user interfaces developed under SARDA. The ATD-2 team has benefitted from the CLT domain expertise and flight operator relationships that the SARDA team developed during the previous research activity.

### 2.2.2 Precision Departure Release Capability (PDRC)

The Precision Departure Release Capability (PDRC)<sup>4</sup> research activity focused on using predicted takeoff times and departure runway assignments from a trajectory-based surface system to improve overhead stream insertion calculations performed by TBFM departure scheduling functions. Figure 2.11 shows the PDRC concept graphic and provides a high-level summary of the research activity.

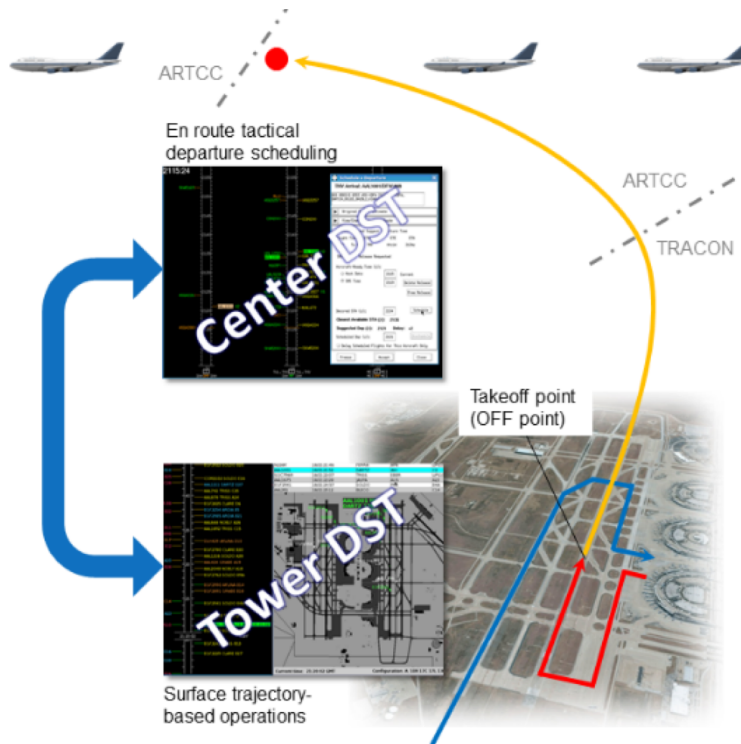

Figure 2.11 - Precision Departure Release Capability (PDRC) uses information from a trajectory-based surface system to improve TBFM tactical departure scheduling.

As indicated in Figure 2.1, PDRC began with a FAA-to-NASA transfer of the operational TBFM software. NASA modified TBFM to interface it with a trajectory-based surface decision support tool that was effectively a surrogate for TFDM. The PDRC integrated system was then used to schedule Dallas/Fort Worth International Airport (DFW) departures that were subject to Approval Request/Call for Release (APREQ/CFR) constraints into Fort Worth Center airspace (ZFW) during the operational evaluation in 2012 and early 2013. PDRC research products were delivered to the FAA in 2013 for use in the TBFM and TFDM programs. A follow-on research activity known as PDRC++ extended this tactical departure scheduling solution to consider TRACON boundary constraints and departures from other airports in a metroplex environment.

ATD-2 benefits from the PDRC team's experience in interfacing TBFM with a trajectory-based surface system and in conducting operational evaluations involving TBFM tactical departure scheduling. Many aspects of the IADS physical architecture incorporate lessons learned from the PDRC operational evaluations. The prototype terminal tactical departure scheduling system developed under PDRC++ forms the basis for the Metroplex Planner (MP) being developed for ATD-2 Phase 3.

### 3 Operational View of ATD-2

The ATD-2 IADS system provides an integrated set of tools for IADS traffic management in metroplex environments. The IADS scheduler provides the coordinated runway schedule which accounts for both arrivals and departures while honoring all known constraints including aircraft type (i.e., taxi speed, wake vortex separation), dual-use runways, converging runway operations, any Traffic Management Initiatives (TMIs), and conflicts at the runway thresholds. The high-level operational view (OV-1) shown in Figure 3.1 consists of a graphic depicting the operational environment surrounded by images illustrating system components and user interfaces from the operational user perspective.

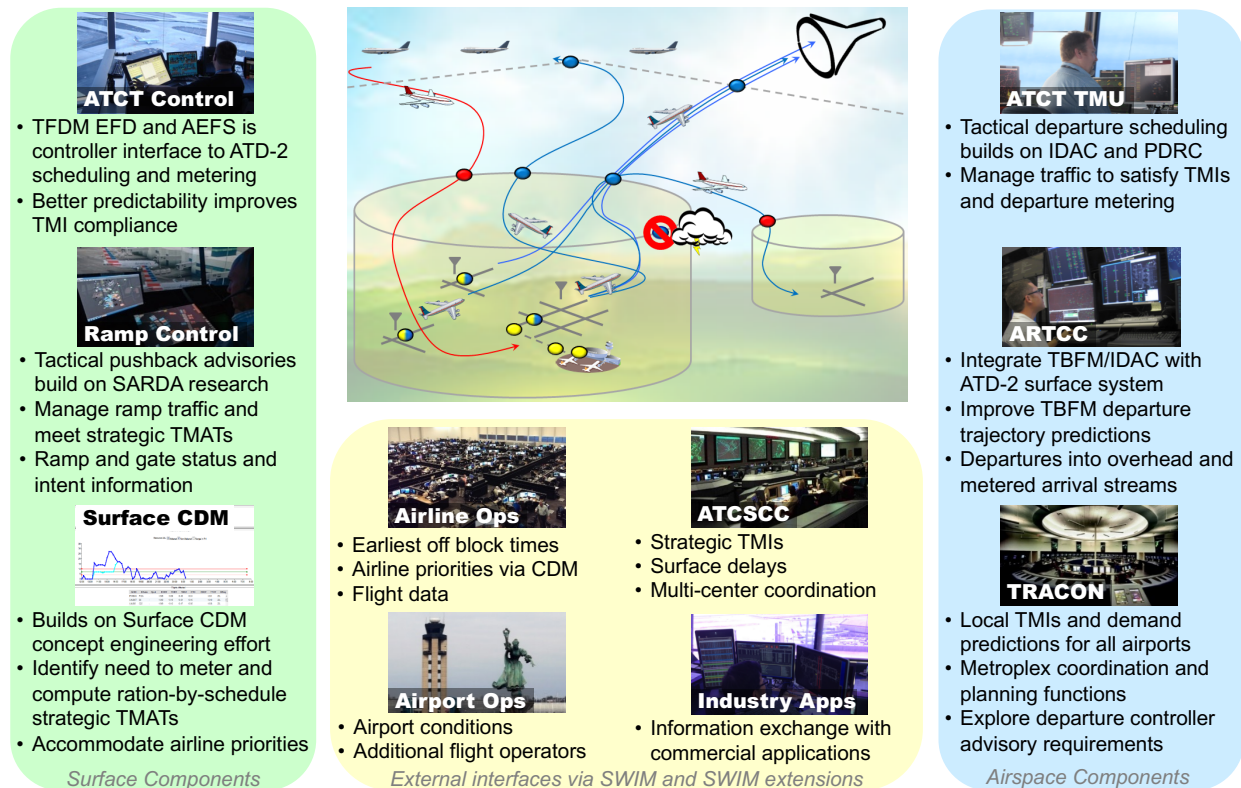

Figure 3.1 - The ATD-2 high level operational concept graphic (OV-1) shows the various user interfaces and system components.

The operational environment graphic in the upper center portion of Figure 3.1 shows air traffic departing from (blue arrows) and arriving to (red arrows) a metroplex terminal environment, along with traffic flow constraints and control points. Overhead stream insertion and strategic flow constraints are illustrated in en route airspace in the upper portion of the graphic. A complete description of the ATD-2 operational environment is provided in Appendix A.

The system components and user interfaces shown in Figure 3.1 are grouped into three colored boxes. The green box on the left contains surface components while the blue box on the right contains airspace components. These will be described in subsections to follow. The yellow box in the lower center illustrates interfaces to external systems that will be facilitated via the FAA's SWIM communications architecture. NASA's ATD-2 effort will address any additional data



sharing requirements through SWIM-compatible extensions and communicate these new requirements to the FAA as part of the research transition process.

The next five subsections describe the primary components of the IADS system, beginning with the ATCT TMU image in the top right of Figure 3.1, and moving clockwise around to the ATCT Control image in the top left of the diagram.

### **3.1 Tactical Departure Scheduling**

The two images in the upper right portion of Figure 3.1 represent the tactical departure scheduling portion of the IADS system. Specifically, the image labeled “ATCT TMU” shows a Tower Traffic Management Coordinator (TMC) using the system to request a release time from the ARTCC (Center) controller during an APREQ/CFR situation. The image labeled “ARTCC” shows a Center TMC using the TBFM interface to schedule the APREQ/CFR departure into the en route traffic flow. This part of the IADS system leverages NASA’s PDRC research activity<sup>4</sup> and FAA investments in TBFM/IDAC.

Tactical departure scheduling is the essential link between the surface and airspace portions of the IADS challenge that ATD-2 is designed to address. TMCs in the Center, TRACON, and Tower will use this part of the IADS system to better plan and implement TMIs, with information provided by the surface (both strategic and tactical) elements of the IADS system. More specifically, information from the surface elements of IADS will provide the Center and TRACON TMCs with a better picture of surface demand and more precise predictions of takeoff times and departure runway assignments, which will improve management of constrained airspace and scheduling into busy overhead flows.

### **3.2 Metroplex Planner (MP) System**

The image in the lower right of Figure 3.1 labeled “TRACON” represents the portion of the ATD-2 IADS system that extends tactical departure scheduling to include terminal airspace constraints and departures from multiple airports in the metroplex environment, known as the Metroplex Planner (MP) system. The initial focus for this function was the TRACON TMU, where TMCs use the MP system to plan and execute terminal TMIs and coordinate with all towers within the metroplex. However, the focus has shifted (in the phase 2) more to the airline operations centers collaborating with the ATCT/ARTCC - TMUs. Yet, the TRACON TMU is still involved in that they are coordinating the TMIs with the tower and the center and entering TMIs into NTML, but they are not the ones submitting or approving reroutes. The MP system will also be used to facilitate joint planning between the TRACON and ARTCC TMCs. See Figure 4.2 for more details.

The ATD-2 demonstration at CLT utilizes only the TMI handling and reconciliation functions of the MP system. Demonstration of its scheduling and coordination capabilities requires a terminal environment with multiple airports, which has started (as part of so called Stormy 19, i.e. end of May to beginning of September of 2019) for Dallas, Texas Metropolitan area airports, specifically, Dallas Fort Worth (DFW) and Dallas Love Field (DAL), American Airlines Integrated Operations Center (IOC), Southwest Airlines Network Operations Center (NOC) and their associated TRACON (D10) facilities.

### **3.3 Strategic Surface Scheduling for Surface Collaborative Decision Making (Surface CDM)**

The image in the lower left portion of Figure 3.1 represents the strategic surface scheduling portion of the ATD-2 IADS system. Specifically, this image depicts the demand/capacity balance projections computed by the strategic scheduling system. This part of the IADS system leverages investments made by the FAA and the Surface CDM Team that has developed the Surface CDM ConOps<sup>1</sup> as well as the prototype DRM system developed to support the Surface CDM concept engineering effort.

The strategic scheduling system continuously monitors the airport demand/capacity balance in a longer look-ahead time and recommends Surface Metering Programs (SMP) with start/end time and associated Target Off-Block Time (TOBT) and Target Movement Area entry Times (TMAT). The strategic scheduler-generated TOBT and TMAT times will be communicated to the surface modeler and surface scheduling subsystem.

### **3.4 Tactical Surface Scheduling**

The image in the left portion of Figure 3.1 labeled “Ramp Control” represents the tactical surface scheduling portion of the ATD-2 IADS system. Specifically, this image shows the Ramp Traffic Console (RTC) and its associated Ramp Manager Traffic Console (RMTC) screen user interface in use by a ramp controller and ramp manager. This part of the IADS system leverages NASA’s SARDA research activity<sup>8</sup> and investments made by US Airways/American Airlines in high-fidelity simulation experiments at NASA’s FFC simulation facility. The RTC user interface displays pushback advisories to the ramp controller and allows the controller to communicate intent information to the IADS system.

A key feature of the IADS system is “fusion” of strategic and tactical approaches to surface metering. The tactical surface scheduler was extended in Phase 2 to include strategic elements. The scheduler continues to predict a precise trajectory-based schedule at the runway, but now it also strategically predicts the need for metering and freezes TOBTs and TMATs in advance of the pilot calling ready for pushback.

In that regard it is useful to note that as part of Phase 2 deployment of the ATD-2 IADS system, all the strategic scheduler logic was added to the tactical scheduler and has fused both Tactical and Strategic schedulers into a one single airport surface scheduler.

### **3.5 Tower Electronic Flight Data (EFD)**

The image in the upper left portion of Figure 3.1 labeled “ATCT Control” represents the Tower EFD portion of the ATD-2 IADS system, replacing paper strips at the Tower. Specifically, the image shows a Tower controller using the FAA’s AEFS prototype at Phoenix Sky Harbor International Airport (PHX). In response to NextGen Advisory Committee recommendations, the FAA has committed to installing AEFS at several airports as part of the TFDM early implementation effort, which has included CLT Tower.

Tower EFD is a crucial link between the IADS system and the Clearance Delivery, Ground and Local Controllers at any given ATCT, as they interact with the departure metering system and implement TMIs on the airport surface. FAA partner organizations have implemented an EFD solution at CLT Tower and have been working with NASA to interface the Tower EFD system



with the IADS system. Initial inclusion of IADS data on EFD has been implemented and the integration of EFD with ATD-2 scheduling (surface and airspace) has been incorporated into the system by the deployment of AEFS at CLT.

## 4 System View of ATD-2

This section presents a system view of the IADS prototype to help the reader better understand how the contributing technologies described above have been integrated in the ATD-2 field demonstration system. Figure 4.1 shows a simplified overview of the major components within the ATD-2 IADS architecture. Although elements of the architecture framework are presented here, the reader should be mindful that this is an overview document intended for a broad audience and not part of the formal system documentation.

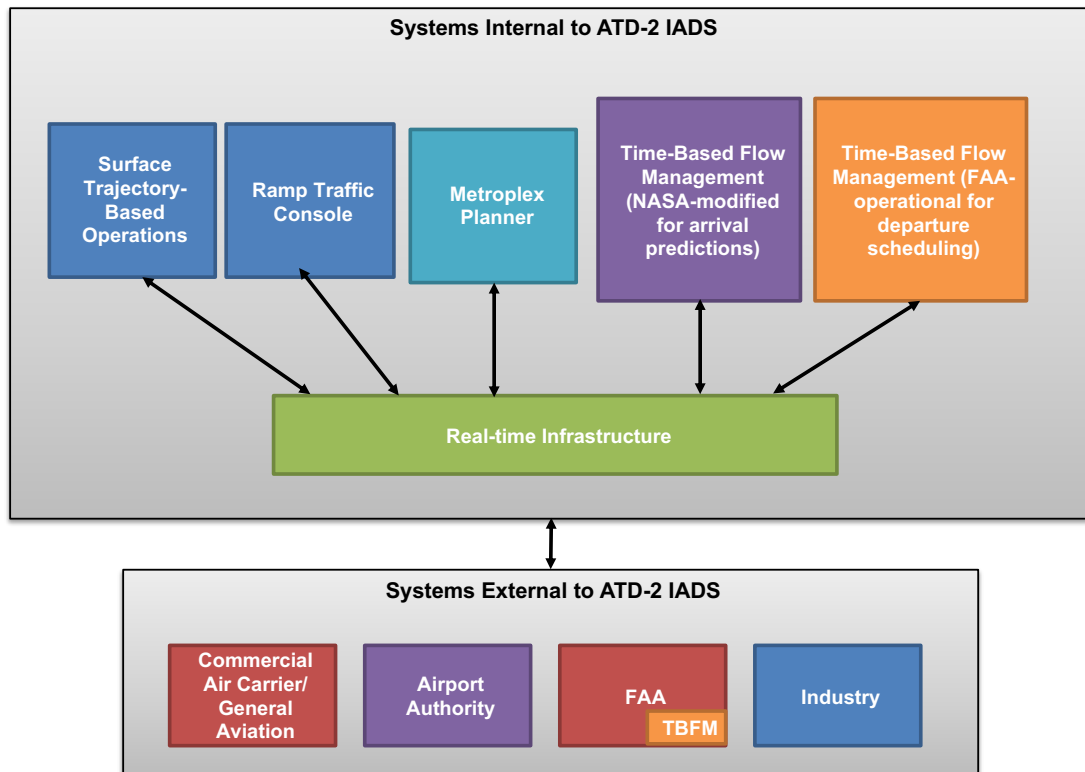

Figure 4.1 - This simplified view of the ATD-2 IADS architecture shows only the major components.

The architecture is divided into two main sections that separate IADS into internal and external systems. A component is considered to be external to IADS if NASA is not expected to have control of the process initialization or maintenance at the operational facility.

Figure 4.2 illustrates the end-state IADS logical architecture to the next level of detail. (Note: the RTC component is expected to be internal to the NASA systems during the field evaluation. Implementing the RTC as an internal component is a field demo artifact, but this implementation gives NASA more research agility. The RTC is a government-furnished example of an industry solution.) Internal IADS system processes shown in Figure 4.2 in blue are a part of the end state design. The following sections discuss each component in greater detail.

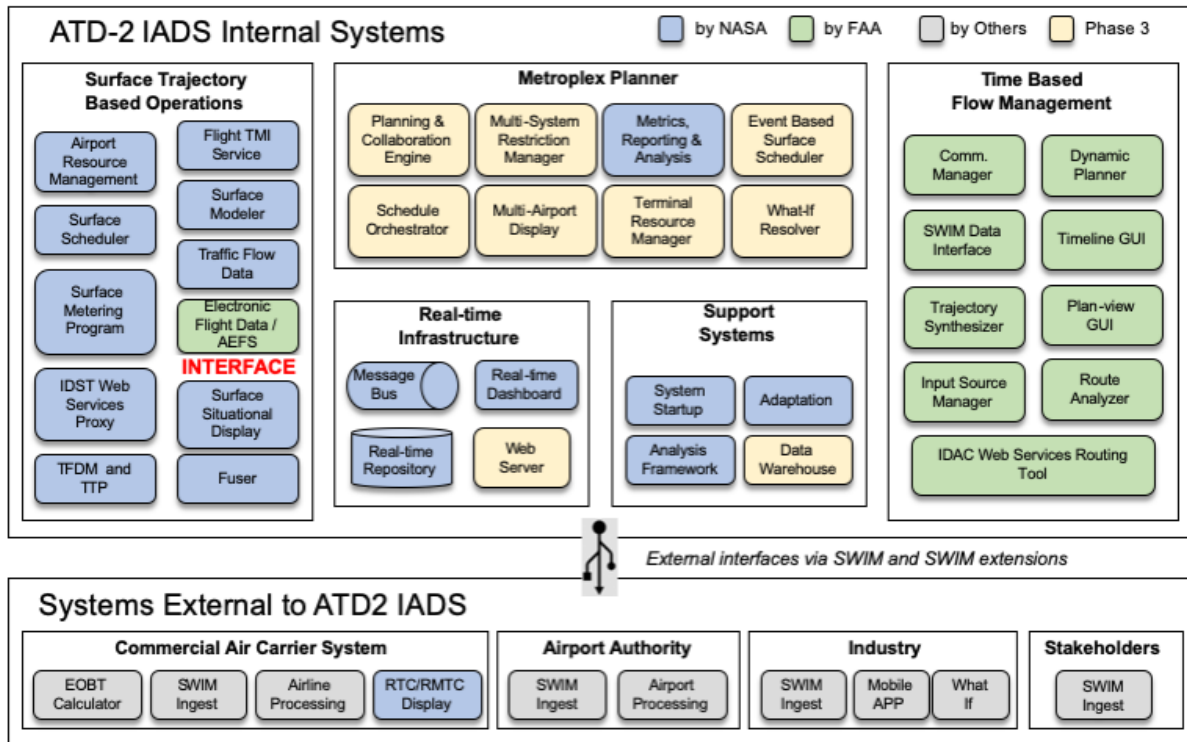

Figure 4.2 - The logical architecture for the IADS field demonstration system is shown to the next level of detail.

#### 4.1 Surface Trajectory Based Operations (STBO)

The Surface Trajectory Based Operations (STBO) portion of ATD-2 IADS is the system element that encapsulates many of the internal IADS elements. The STBO system is a collection of surface trajectory-based capabilities that provide IADS automation for the airport surface. It includes capabilities such as strategic and tactical surface scheduling, electronic flight data capability, interaction with other NAS Decision Support Tools ( ) like TBFM, airport configuration and general awareness capabilities, and outgoing data feeds to industry. The STBO Client is the primary user interface that enables the Tower personnel to interact with the system for such automation.

The Multi-Function Display (MFD) is the software that houses the STBO Client, the RTC/RMTC, the Surface Metering Program (SMP) interface, and the real-time dashboard user interfaces (this is the “green bar” on the controller station, and not part of the software architecture). The various users/positions will have a primary/home/default display on their MFD, but users will be able to access and customize their view. Figure 4.3 provides a detailed STBO block diagram for the baseline IADS, as implemented at CLT. (Note: the end state Ramp Traffic Control / Ramp Manager Traffic Control is considered to be external to STBO, but within IADS.) The DRM, as conceptualized in the Surface CDM ConOps,<sup>1</sup> is broken down into more specific functional elements in the STBO system: surface modeling (Surface Modeler), and surface scheduling (both Tactical and Strategic Scheduler).

STBO has a “What-if” scenario feature that shows the user what the effect of the considered change is predicted to be if the user were to implement the change. This is accomplished by the primary STBO instance making a request to a secondary STBO instance whose sole purpose is to

handle what-if scenario calculations. More details on the use of the what-if scenario feature may be found in section 4.1.3.8 of the ATD-2 ConUse document.<sup>2</sup>

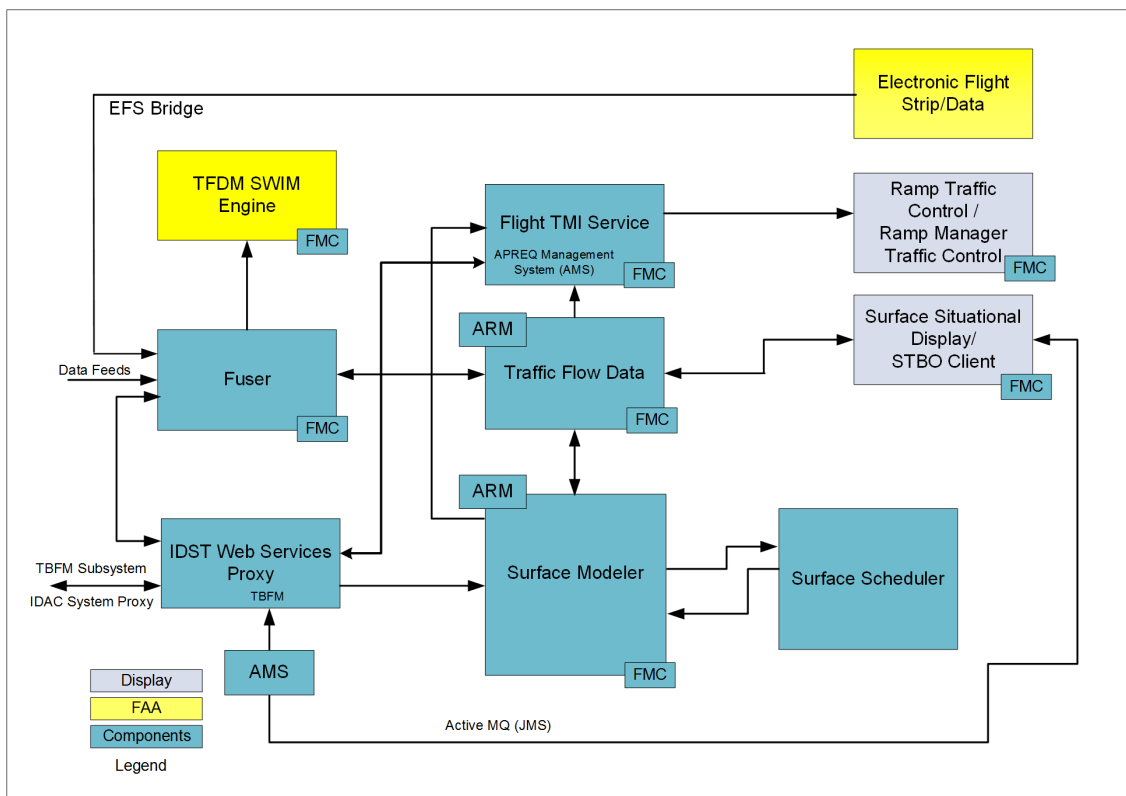

Figure 4.3 - The ATD-2 STBO Block diagram is shown as it is implemented in Phase 1.

#### 4.1.1 Surface Modeler

The Surface Modeler tracks, updates, and disseminates information on key surface events. Actual surface event data (e.g., Actual OUT information) is used in conjunction with derived data and model processing logic to produce a single cohesive view of airport operations that is common among other ATD-2 IADS components. It contains enough information about the airport surface and how the ATCT handles traffic in different scenarios to generate good estimates of undelayed taxi time for each flight. At a rate of once every ten seconds, the Surface Modeler leverages this view of the surface operations to generate predictions of the Undelayed Take Off Time (UTOT) for departures. This approach is significantly different than having a lookup table that leverages empirical data that was not derived from trajectory-based information. Trajectory Based Operations (TBO) are part of the FAA’s NextGen strategy/roadmap. For arrivals, the Surface Modeler mediates between different data sources to generate the most accurate Undelayed Landing Time (ULDT).

The name “Surface Modeler” was chosen because it best fit the core function and minimized confusion among the other surface scheduler (which includes both tactical and strategic scheduling). The name ‘Model’ was also chosen because this capability shares many similar duties to other NAS components that provide similar functions (e.g., NAS Common Situational Model (NCSM), in the TFMS system).

**4.1.1.1 Component General Description**

The Surface Modeler calculates the undelayed times for the STBO system and provides this output to other components for surface scheduling and metering purposes. This component maps to capabilities within the TFDM Surface Management Process (SMNP) Computer Software Configuration Item (CSCI), although some functions exist in the ATD-2 surface modeler that are currently not specified in the TFDM system specification and vice versa.

The Surface Modeler bases its calculations on the latest surface adaptation for a given airport. The surface adaptation contains the airport map (i.e., Geographic Information Systems data from airport authorities and other government agencies), as well as airspace fixes, parking gates, runways, spots, taxiways, taxiway polygons, intersections, runway configurations, and departure scenarios. The surface adaptation offers a complete computer-based representation of the physical airport and attempts to capture how the airport is used. It utilizes integrated software decision trees to reduce the adaptation complexity.

**4.1.1.2 Functions**

The core Surface Modeler functions include computing the three-dimensional (3D) (x,y,t) surface trajectory from the gate (OUT) to the runway (OFF) for departures, and from the runway (ON) to the gate (IN) for arrivals, based on the expected airport/runway configuration and gate assignment. The Surface Modeler uses surveillance data, when available, to detect the position of aircraft and update its trajectory prediction. The Surface Modeler uses the default shortest path when the coded taxi routes are not available in the adaptation, including using the airport resource information to select the available routes. It predicts runway usage, surface trajectory, and gate conflicts and also links flights into a line-of-flight for each airframe.

Another important function of the Surface Modeler is to detect and determine the current flight state for each aircraft, which is used for taxi trajectory prediction and flight scheduling. Table 4-1 lists the flight states, their definitions, and the logic for transitioning to that state. The surface flight state logic starts from the first row in the table and the proceeds down list. The flight will be put into the final flight state that had the criteria met.

*Table 4-1 Flight Status/States are necessary for taxi trajectory predictions and flight scheduling.*

Flight State / Flight Status	Definition	Transition Logic
<b>Unknown</b>	Default not-set value	None
<b>Scheduled Out</b>	<p>Departure date and time for flight has been published by flight operator and the flight is a departure from the ATD-2 airport</p> <p><i>Note: Scheduled out and in are one state in the model. They are displayed differently on the client depending on</i></p>	<ul style="list-style-type: none"> <li>• Departure flight has a scheduled runway departure time, as generated by the IADS system.</li> <li>• OR: Departure flight had pushed back but has returned to the gate.</li> <li>• OR: Departure flight was Suspended by automation (see “Suspended” below) but an updated runway time is received.</li> </ul>

Flight State / Flight Status	Definition	Transition Logic
	<i>whether or not the flight is an arrival or a departure.</i>	
<b>Scheduled In</b>	Arrival date and time for flight has been published by flight operator and the flight is an arrival to the ATD-2 airport	<ul style="list-style-type: none"> <li>• Arrival flight has a scheduled runway arrival time, as generated by the IADS system.</li> </ul>
<b>Pushback</b>	Departure flight is in the process of pushing back or has left the gate, but is not yet taxiing in the ramp	<ul style="list-style-type: none"> <li>• Departure flight has not yet completed pushback process but has actual OUT time from the flight operator.</li> <li>• OR: Departure flight received pushback clearance from ramp controller input.</li> <li>• OR: Surface surveillance detects that flight has pulled away from gate.</li> </ul>
<b>Out</b>	Departure flight is taxiing in ramp	<ul style="list-style-type: none"> <li>• Departure flight has pushed back AND: <ul style="list-style-type: none"> <li>○ Departure flight received clearance from the ramp controller to proceed to the spot.</li> <li>○ OR: Surface surveillance detects departure flight tracks in ramp area away from the gate.</li> </ul> </li> </ul>
<b>Taxiing AMA</b>	Departure flight is taxiing in Airport Movement Area (AMA)	<ul style="list-style-type: none"> <li>• Departure flight has actual SPOT time (crossed spot into AMA).</li> <li>• OR: Surface surveillance detects departure flight tracks in AMA.</li> </ul>
<b>In Queue</b>	Departure flight is in the runway queue	<ul style="list-style-type: none"> <li>• Surface surveillance detects aircraft has entered runway departure queue area designated by adaptation.</li> </ul>
<b>Departed</b>	Departure flight has taken off from airport (wheels up)	<ul style="list-style-type: none"> <li>• Departure flight speed and location (over runway or outside of airport boundary) indicates takeoff roll has begun.</li> </ul>
<b>En route Arrival</b>	Flight is in ARTCC airspace	<ul style="list-style-type: none"> <li>• Initial state for arrival flight with position tracks.</li> </ul>
<b>Terminal Area Arrival</b>	Flight is in TRACON airspace	<ul style="list-style-type: none"> <li>• Radar detects touch-and-go arrival aircraft.</li> <li>• OR: Radar detects arrival aircraft tracks in Terminal airspace (inside TRACON boundary, as defined in adaptation).</li> </ul>
<b>On Final</b>	Arrival flight is lined up with runway and	<ul style="list-style-type: none"> <li>• Radar detects arrival aircraft tracks within threshold distance to land on arrival runway.</li> </ul>

Flight State / Flight Status	Definition	Transition Logic
	descending to land at destination airport	
<b>On</b>	Arrival flight is detected to be on the airport surface and taxiing in AMA	<ul style="list-style-type: none"> <li>• Surface surveillance detects arrival aircraft tracks within airport boundary.</li> <li>• OR: Arrival flight has actual ON time.</li> <li>• OR: CLT specific case: Arrival flight in ramp uses taxiways M-C briefly before returning to ramp.</li> </ul>
<b>In Ramp</b>	Arrival flight is taxiing in ramp	<ul style="list-style-type: none"> <li>• Arrival flight has landed AND: <ul style="list-style-type: none"> <li>○ Surface surveillance detects arrival aircraft tracks in ramp area.</li> <li>○ OR: Arrival flight has actual SPOT time, but is not yet in the In-Gate state.</li> </ul> </li> </ul>
<b>In</b>	Arrival flight has reached the gate	<ul style="list-style-type: none"> <li>• Arrival flight has actual IN time.</li> <li>• OR: Surface surveillance detects arrival aircraft tracks within a configurable distance of gate (default 100 feet).</li> <li>• OR: Surface surveillance tracks are stale (time configurable), and last position is near gate, AND Flight is already in the Ramp (state was Ramp Taxi In).</li> <li>• OR: Arrival flight cleared to gate by ramp controller.</li> </ul>
<b>Suspended</b>	Flight is postponed to a later time	<ul style="list-style-type: none"> <li>• Departure flight is N minutes (time configurable) past its estimated departure, APREQ, or EDCT time.</li> <li>• OR: Arrival flight is N minutes (time configurable) past its estimated arrival time.</li> <li>• OR: Ramp controller marks the flights as Suspended.</li> </ul>
<b>Cancelled</b>	Flight will not operate	<ul style="list-style-type: none"> <li>• Ramp controller marks the flight cancelled.</li> <li>• Or: Flight operator indicates that flight is cancelled via SWIM TFMS data feed.</li> </ul>
<b>Return to Gate</b>	Flight is assigned to Return to Gate (even though it was pushed back from the gate at some point prior to re-entry to the gate) due to various reasons	<ul style="list-style-type: none"> <li>• Flight operator decides to move the flight back to the gate via SWIM TFMS data feed.</li> <li>• OR: Ramp Controller indicates the flight as return to gate and scheduler treats it accordingly.</li> </ul>

### 4.1.1.3 Inputs/Outputs

As depicted in Figure 4.4, the Fuser (section 4.1.5) provides input data for the Surface Modeler from multiple data feed sources. The input data include flight plans, predicted runway, assigned gate, TFDM SWIM Engine data, TBFM data, surface surveillance, and flight specific events.

The ATD-2 Airport Resource Management (ARM) functions are meant to align with the TFDM ARM functional area. In ATD-2, the ARM component (section 4.1.7) provides input data from available airport resources for the surface modeler (e.g., current airport configuration, runway utilization intent from the FAA ATC, runway updates from the ATC or pilot due to operational necessity, default runway assignments). The ARM imports the setting for airport configuration and scenario, which in turn sets rules for predicting runway utilization; it also provides information on the closing of runways, taxiways, and ramps.

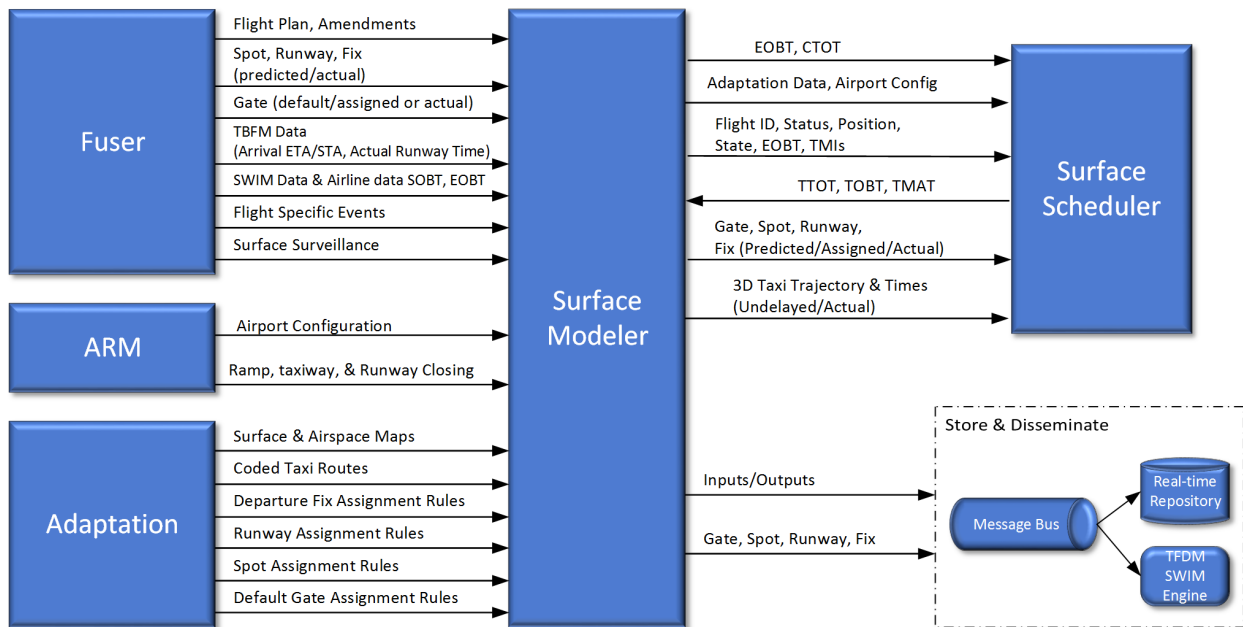

Figure 4.4 – The ATD-2 Surface Modeler component consumes/produces a variety of data.

The adaptation is read, processed, and merged with the flight plan data, the flight operator inputs, and the ATC inputs to calculate the flight-specific data, such as the gate assignment, spot assignment, taxi route, taxi speed, etc. The surface modeler utilizes a set of decision trees from the adaptation that provide the criteria or rules for assigning default flight-specific data values.

The Surface Modeler output is a combination of observed truth (actuals) and predictions. The output is expected to pass to the Surface Scheduler, as well as to many user-facing interfaces (e.g., some surface model output updates the STBO Client and the RTC, prior to going through the schedulers). The output for departures consists of the 3D surface trajectory and times from the gate through the spot to the runway. If the flight has left a location (e.g., gate, spot, runway), the time output is the actual time. If the flight has not yet reached a location, the time output is the undelayed taxi time. For arrivals, the surface trajectory and times are from the runway to the gate: actual time if aircraft is past a location, undelayed time if it is not past.



Note: Figure 4.4 illustrates logical data flow. It is not intended to capture the physical flow of messages sent between software processes. Data between the components actually flows through Java Message Service (JMS) publish/subscribe messaging, from which the other components read the data. The components do not have point-to-point communication.

#### ***4.1.2 Surface Scheduler***

In the earliest phase of development plan of the ATD-2 system, it was envisioned that the surface scheduler consisted of two separate and distinct scheduling programs, Tactical and Strategic schedulers. During the course of deployment of Phase 1 and into the Phase 2 field demonstration and system evaluation, the two scheduling programs were combined together - integrated into what is now the fused Surface Scheduler.

The tactical part of the scheduler provides de-conflicted surface trajectories and generates Target Off-Block Times (TOBTs), Target Movement Area entry Times (TMATs), and Target Takeoff Times (TTOTs) to provide specific event times for pushback, movement area entry, and wheels up to the users of the system. The de-conflicted surface trajectories from the tactical scheduler are calculated based on the Earliest Off-Block Times (EOBT) that is provided by the flight operator (such as American Airlines at CLT), runway wake vortex separation criteria and Controlled Takeoff Times (CTOT) (e.g., APREQ/CFRs, Expect Departure Clearance Times (EDCTs)) that are provided by FAA systems.

The process begins with the surface trajectory prediction that receives aircraft state, flight intent, and trajectory modeling outputs. Aircraft state is provided by the Surface Modeler as described in the previous section. Pushback intent is communicated as the Earliest Off-Block Time (EOBT) acceptable for a given flight, as well as hold advisories entered by the ramp controllers. Initial scheduled time, also known as Initial Off-Block Time (IOBT) is the initial estimate of pushback time. The airline updates the pushback time estimates by providing updated EOBTs. Generally, high-quality EOBT updates will be available about 30 minutes prior to departure. However, closer to actual departure time, EOBTs are refined and updated through flight plan inputs and other information provided by flight operators in the ramp tower or operational control center using situational information such as the status of passenger boarding and baggage loading, etc.

It should be noted that the strategic portion of the scheduler is one of the planned Surface CDM capabilities integrated into ATD-2, and is also referred to as the Strategic Surface component of the system. To assist with strategic scheduling, a Departure Reservoir Manager (DRM) system, which was developed by Metron Aviation as part of the Surface CDM concept engineering effort led by the FAA, was delivered to NASA as a standalone product for ATD-2. This system was used to collect strategic scheduling data during Phase 1 that provided guidance and design decisions for the Phase 2 fusion effort. The capabilities in this tool later evolved into the design and deployment of the Surface Metering Program (SMP) capabilities.

The logic of the IADS scheduler is described in Figure 4.5 at a high level. The scheduler interaction with Surface Modeler to exchange tracks, updates, and disseminates information on key surface events to generate a single cohesive view of airport operations. Actual surface event data (e.g., Actual OUT information) is used in conjunction with derived data and model processing logic to produce a single cohesive view of airport operations. At a rate of once every ten seconds, the surface modeler leverages this view of the surface operations to generate predictions of the Undelayed Take Off Time (UTOT) for departures. For arrivals, the surface

modeler mediates between different data sources to generate the most accurate Undelayed Landing Time (ULDT). In addition to the UTOT and ULDT, the model assigns each aircraft to a Scheduling Group which is one of the data elements used to select the next aircraft to schedule.

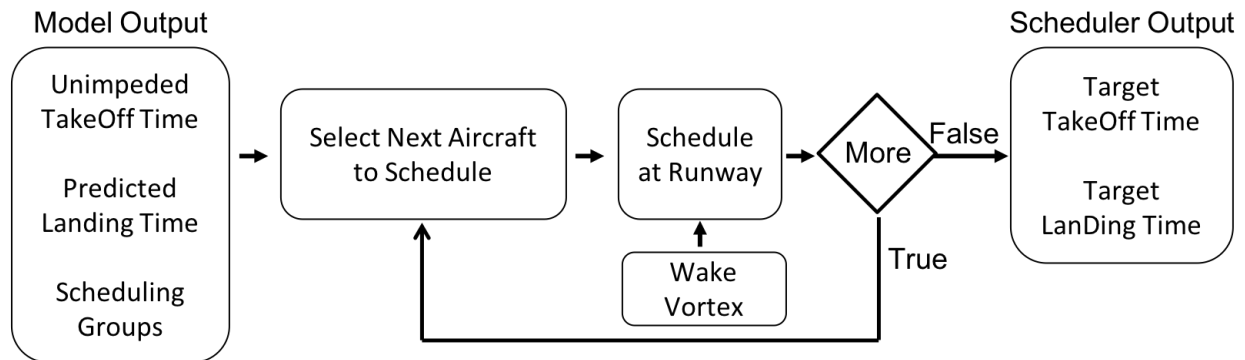

Figure 4.5 – High level design of the IADS scheduler

Using UTOT, ULDT, and Scheduling Groups, the scheduler implements two main processing steps. The scheduler first selects the next flight that will be inserted into the schedule, based on either first-come, first-served (FCFS) or first-scheduled, first-served (FSFS) depending on the surface metering criteria, and then inserts the aircraft at the earliest feasible time such that all wake vortex constraints are satisfied. The feasibility of the scheduled time is defined as at or after the UTOT or ULDT for departures and arrivals, respectively.

#### 4.1.2.1 Component General Description

To Ramp Controller, the surface scheduler provides take off time predictions and pushback advisories, if needed, that reflect the latest flight status, the TMI constraints, and guidance on how to meet these times. Surface metering is the activity of holding flights in the non-movement area (ideally at the parking gate) to reduce surface congestion due to runway demand/capacity imbalance. Surface metering is expected to occur during peak traffic periods at the airport. There are two surface metering modes: sequence-based metering, which implements the count-based metering methodology that American Airlines ramp controllers at CLT were using prior to ATD-2 (also known as “departure sequencing”), and time-based metering, which is the time-based pushback advisory for individual aircraft using the surface scheduler, in which the metering triggering decision is made based on the prediction of excess queue time of departure flights, and gate hold times are calculated based on the target excess queue time. In the tactical surface metering environment when time-based surface metering is turned on and the metering has been triggered, advisories are provided at least 10 minutes before pushback ready for applicable flights (see Scheduling Groups in section 4.1.2.2), and these advisories are recomputed every 10 seconds, with a freeze when the pilot calls in and the ramp controller places the flight in hold. In the strategic surface metering environment, on the other hand, pushback advisories for the flights included in a SMP are provided to the ramp controller and the pushback advisories, i.e., TOBTs, are frozen when the time before the TOBT reaches to the value defined by the Static Time Horizon (STH), e.g., 15 minutes. The Ramp Control user interfaces are the Ramp Traffic Console (RTC) and the Ramp Manager Traffic Console (RMTC) Graphical User Interfaces (GUIs) (section 4.4).

To air traffic control, the surface scheduler provides the latest prediction of what the arrival and departure demand will be on each of the runway resources, as well as playing an important role between the Tower TMC and the Center TMC for scheduling flights subject to a TMI. It retains the Controlled Take-Off Time resulting from this coordination. An enhanced STBO Surface Situational Display (section 4.1.9) and the EFD (section 4.1.8) function as the user interfaces for the Tower TMC.

As was mentioned above, one of the key features of the ATD-2 system is the “fusion” of both strategic and tactical approaches into a single surface scheduling and metering function. The goal of the Phase 2 Fused IADS Demonstration has been to develop a fused system, where the predictions of demand/capacity imbalance for a longer look-ahead time (e.g. several hours in the future) and the results of strategic scheduling will be used by the same scheduling algorithm used for tactical surface scheduling in a seamless manner.

The SMP capability and its Surface Metering Display (SMD) user interface contains all the functions required to set default parameters, render strategic and/or tactical prediction information, and obtain commands and other required inputs from the users.

#### ***4.1.2.2 Functions***

The surface scheduler provides the Target Off-Block Time (TOBT), Target Movement Area entry Times (TMATs), and associated advisories to the Ramp Control and ATC personnel. For flights subject to APREQ restrictions, the surface scheduler provides the Earliest Feasible Takeoff Time (EFTT) to TBFM/IDAC, for use in generation of its airborne Estimated Time of Arrival (ETA) at the meter point and as a basis of tactical TMI negotiation. TBFM/IDAC provides the Controlled Takeoff Time (CTOT) to the scheduler for its inclusion in the overall airport scheduling. The scheduler then provides pushback advisories to the ramp controller that assist in meeting that CTOT.

The TOBT, TMAT, and TTOT reflect all known constraints, including wake vortex separation, dual-use runways, Converging Runway Operations (CRO), and TMIs. The scheduler enables the flight operators to prioritize among their company’s own flights. For flights with no TMI, the TTOT is an estimate based on modeling the controller’s best practices (i.e., a prediction, not an advisory), and the TTOTs for metered and TMI flights are the result of scheduling automation.

The scheduler is always running and updating every 10 seconds with estimates for both arrivals and departures. The pushback advisories are always displayed to ramp personnel for flights with CTOTs regardless of whether surface metering is activated or not. However, the display of pushback advisories to ramp users on the RTC/RMTC for surface metering guidance depends on the metering mode. During time-based metering, gate-hold and pushback advisories are displayed on the RTC/RMTC. When sequence-based is used or time-based metering mode is not active, metering advisories are not displayed.

The surface scheduler ingests its own site adaptation files plus predefined scheduler parameters. It is structured based on a simplified graph model of Nodes in a Network. A Node is a point at which some constraint must be met (e.g., gate, spot, taxiway intersection, runway, departure meter fix, etc.) The Nodes are joined into a network by segments (e.g., graph edges) that hold properties, such as transit times, delay margins, and uncertainty buffers. Graph nodes are not explored as in a traditional graph model (i.e., it’s not trying to find an optimal path – rather the scheduler is following the path predicted by the surface modeler).

Assigning aircraft to Scheduling Groups is a core function of the surface modeler. The scheduler utilizes Scheduling Groups for departure flights to determine the applicable rules for flight readiness prediction, scheduling, metering, and display of advisories. The Scheduling Groups are used within the Select Next Aircraft to Schedule logic block (Fig. 4.6) which dictates the order that aircraft are inserted into the schedule. The Scheduling Groups and selection of the next aircraft to insert into the schedule are guided by a heuristic that flights with higher certainty in their UTOT predictions should have higher precedence in scheduling. The main Scheduling Groups for departure aircraft ordered from highest certainty to lowest certainty include: Active, Ready, Planning, and Uncertain. For departures, assignment to the different groups is dependent upon the state of the flight and the EOBT. Any departure that has already pushed back is assigned to the Active group. Aircraft that have called ramp controllers for pushback and are put on hold are assigned to the Ready group. Assignment to the Planning group and Uncertain group is based on the flight's EOBT and has evolved throughout the Phase 1 field evaluation.

Originally, in Phase 1, the status of EOBT with respect to current time was used to assign departure aircraft at the gate to two Scheduling Groups: Uncertain and Planning. All departures started in the Uncertain group and transitioned to the Planning group when their EOBT was within the planning horizon defined as current time plus ten minutes. This approach prioritizes aircraft with an EOBT within ten minutes of current time and ensures that these aircraft are scheduled into the available runway capacity before any aircraft whose EOBT is outside of the planning horizon.

In the current implementation, the scheduler assigns any aircraft with an EOBT to the Planning group. The Uncertain group is reserved for aircraft that do not provide an EOBT or do not call ready within 13 minutes of their EOBT. Because aircraft are no longer transitioning from the Uncertain group to the Planning group ten minutes prior to EOBT, the TTOTs that are assigned to aircraft at the gate with an EOBT outside of the ten-minute planning horizon better reflect the true delay that aircraft will experience.

Flights are scheduled by an "order of consideration" approach. As part of the Phase 1 field evaluation, the order of consideration was used to achieve either a First-Come, First-Served (FCFS) or First-Scheduled, First-Served (FSFS) order (per S-CDM ConOps recommendation of runway usage) within the scheduling group, while considering the priority of flights and TMIs.

However, the role of the Scheduling Groups and order of consideration has changed post Phase 1. Originally, in Phase 1, the Scheduling Groups and UTOT of unscheduled aircraft were sorted to generate the order of consideration which defined the sequence that aircraft would be inserted into the schedule. To build the order of consideration, departures were first sorted by Scheduling Group, then within each group departures were sorted by UTOT for Active and Uncertain and sorted by Scheduled Off-Block Time (SOBT) + UTOT for Planning. The SOBT is provided by the airline operators and is not the IADS schedule. In Phase 2, however, the FSFS rule, i.e., SOBT + UTOT, is applied only when there are unscheduled flights whose excess taxi time is predicted to exceed the set target excess queue time.

The strategic scheduler component evaluates the demand/capacity balance of the runways and recommends a surface metering program (SMP) if there is an imbalance (see section 4.1.3 for more information on SMP and the SMP service). It applies the SMP parameters set via the SMD user interface in evaluating the demand/capacity. The scheduler calculates TMAAT times, taking into consideration several factors. It will comply with the EDCTs and APREQ/CFR times, if

applicable, as provided by the Flight TMI Service. It will apply the surface trajectory prediction, consider the EOBT and gate assignment from flight operator supplied data, and consider flight operator provided preference while determining the TMAAT time.

The scheduler will adjust TMAAT times based on flight operator preferences (e.g., intra-flight operator substitutions using priority status). It will also use surveillance to detect actual spot arrival and takeoff times, in order to evaluate TMAAT conformance and other performance metrics.

The SMP user interface provides predicted demand based on flight operator schedules and an estimated departure and arrival capacity based on actual gate occupancy and runway configuration information of the airport resources. It identifies a predicted demand/capacity imbalance and the recommended surface metering to resolve it. It also provides entry options for rejecting or affirming an SMP, adjusting the SMP parameters such as SMP Lead Time and Static Time Horizon (STH), and potentially modifying an SMP recommendation. The ATCT personnel and Ramp Manager collaborate to maintain and manage the SMPs.

Figure 4.6 illustrates the primary data flow into and out of the surface scheduler, from the standpoint of the primary producers and consumers of the data. Note: the actual physical data flow itself is through Java Messaging System (JMS) publish/subscribe messaging. Thus, the components themselves are not required to perform process level handshaking and other point-to-point protocols.

The Surface Modeler component (section 4.1.1) provides the undelayed taxi times to the surface scheduler, along with its detailed flight-specific modeled input. The surface scheduler uses this undelayed time as the basis for developing its schedule. In this way, consistent trajectory input can be provided to the surface scheduler.

The Airport Resource Management (ARM) logical component (section 4.1.7) is shown as supplying the airport configuration data. There are other constraints that the surface scheduler uses which originate from ATC intent information.

The Flight TMI Service (section 4.1.10) provides common TMI scheduling for the STBO system. This service stores the TMI information on flights already committed to (e.g., a controlled time exists in the system) and responds to new TMI scheduling requests.

The strategic and tactical scheduler design are generally speaking very similar, and that is to help achieve a number of architectural objectives that are geared toward future harmonization amongst the schedulers, comparative analysis & research, system maintainability, scalability, and reuse.

Data that is useful for operational analysis, simulation input, and/or detailed system debugging purposes will be archived and disseminated to other users, as required.

The key aspect of data flow is the interactions with the SMD and the data that is disseminated for broader system use. The surface scheduler provides notifications to the SMD of demand/capacity imbalances and associated SMPs, as well as notifications when events like compression and reassignment are recommended. Compression and re-assignment are handled automatically in the surface scheduler. It should be noted that there is no compression or reassignment logic in the current version of the system. However, it is included in the future release /implementation. Both of these are for strategic CDM concept that came from S-CDM concept of operations document.

The primary output product that ATD-2 uses from the surface scheduler is the TOBT, TMAT and TTOT times. The surface scheduler inputs/outputs, parameter changes, and advisories will be disseminated to the other system users/processes that are required and will be stored in the database.

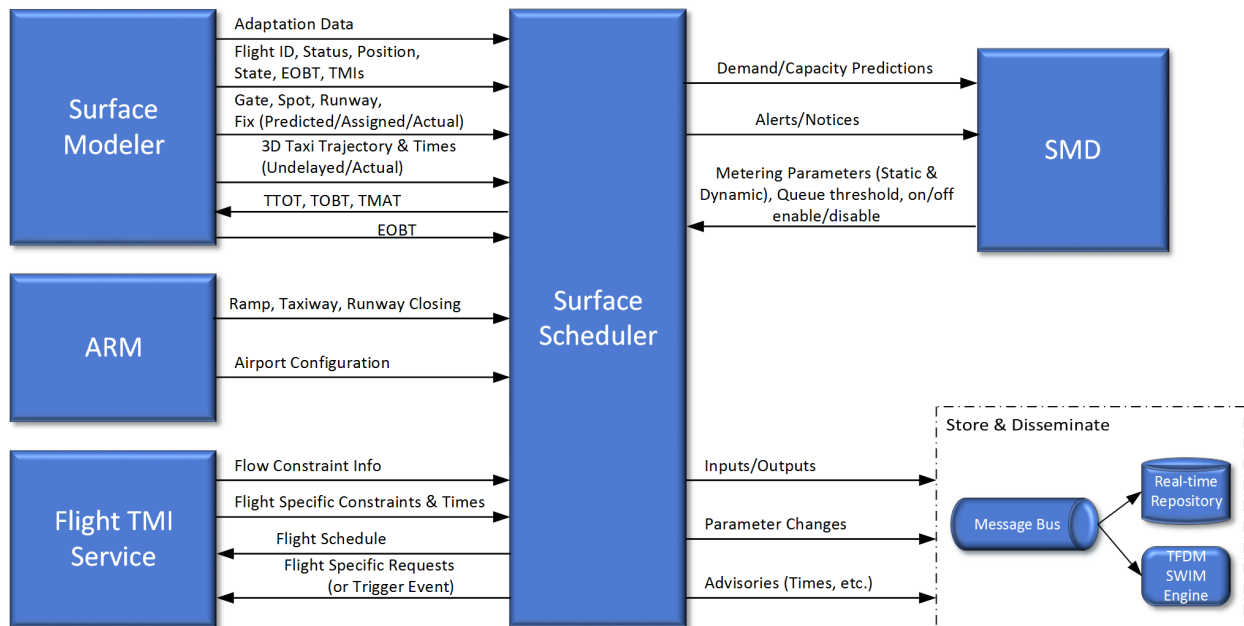

Figure 4.6 – The Surface Scheduler component consumes/produces a variety of data.

### 4.1.3 Surface Metering Program (SMP) Service

The ATD-2 IADS system provides options for the collaborative surface metering program service, a way to specify the surface metering mode currently in use by the facility. The strategic planning was incorporated into the tactical scheduler (Phase 1) to provide predictions at the longer look-ahead timeframe and to provide advance notice for metering, allowing for the generation of TOBTs and TMATs with more lead time. The SMP Service was added/leveraged from the Surface CDM/TFDM concepts.

The specific metering modes are: Metering Off, Sequence Based Metering, and Time-Based Metering.

These modes are not only for the benefit of ramp controllers, but also for ATCT personnel, the TFDM prototype SWIM feed, and post analysis needs. It is part of the integrated ATD-2 IADS system. However, the modes and key parameters entered is used by the scheduler supporting transitions between the metering modes (e.g., sequence-based transitioning to time-based) in CLT. The metering status is shared with the STBO Client and the surface scheduler, displayed on the Surface Metering Display, shared with the TFDM SWIM engine, and stored in output data for analysis.

#### 4.1.3.1 Component General Description

Time-Based Metering:

The time-based metering advisories are NASA ATD-2's flagship scheduling technology as provided by the surface scheduler to the RTC/RMTC. The demand in the departure runway is measured by the excess taxi time of individual aircraft in the planning horizon and this excess taxi time above the target excess queue time is shifted to the gate by holding aircraft at the gate. The advisories are also time-based because they are communicated as a time to the ramp controllers and pilots. They use time-based estimations that leverage trajectory-based operations on the airport surface.

Communicating an expected pushback time creates a common goal for all parties to work toward, and allows multiple flights to depart at the same time if necessary, based upon their relative location from the parking gate to the spot, and in turn to the runway.

Time-based delay estimation allows more fine-tuned control over how much delay the air carrier would like to take at the departure gate versus the runway. Time-based metering is not based on a single static value that is passed along, such as a count of departures in the departure queue. Rather, it is based on an assessment of the runway utilization and the demand for each system resource.

The nominal way of running time-based metering is in "auto" mode. In this mode, the system seeks to utilize the existing runway capacity with the available demand. The purpose of "upper" and "lower" threshold is to provide stability in surface metering status between activated or deactivated, and the values can be determined by the ramp manager or ATC personnel who know of certain conditions that tend toward a lower or greater demand for the runway.

#### Sequence-Based Metering:

The sequence-based or count-based surface metering system also known as "departure sequencing" is the legacy surface metering system that CLT Ramp used prior to the deployment of ATD-2 IADS system and that ATD-2 IADS system continues to support. It is largely a sequence-based metering system since the first flight to go into metering hold is generally also the first flight to come out of metering hold. The time that a flight will be released from metering is not known (because it is not time-based), but the sequence that flights will be released is known.

The sequence-based metering is implemented in ATD-2 IADS system for several reasons. First, it is what CLT ramp controllers are used to. Before introducing time-based metering controls to the users, it was decided to provide that function in the system to ease the controllers into the RTC/RMTC features using a system they are somewhat familiar with. More importantly, sequence-based metering is robust for a fairly large uncertainty. It may be possible to use sequence-based metering in time periods where time-based advisories are not as stable due to anomalous events.

However, it should be noted that sequence-based metering has not been used since the post Phase 1 implementation of the system, yet the feature is still available.

#### **4.1.3.2 Functions**

The SMP user interface provides the user with predicted demand based on flight operator schedules and an estimated departure and arrival capacity based on actual gate occupancy and runway configuration information of the airport resources. It notifies the user of a predicted demand/capacity imbalance and the recommended SMP to resolve it.

When operating in Time-Based Metering, the ATD-2 system will predict the need for metering and the subsequent gate holds to meet the metering criteria. The ATD-2 system will propose new Surface Metering Programs (SMPs) for specific runways when the predicted time in queue exceeds the specified upper threshold.

The SMP predicts when metering will be needed in advance, allowing users to collaborate on a recommended metering program by affirming or rejecting the recommended SMP. ATD-2 SMPs are automatically adjusted at regular intervals based on the latest data. The ATCT TMC collaborates with the ramp manager to set the desired metering parameters and make the decision to affirm or reject an SMP. If an SMP is affirmed, the metering will become active at the appropriate time; if an SMP is rejected, then metering is considered inactive. If no action is taken, then metering will remain inactive. Targets and Thresholds are set to the same values as they were in the Phase 1 tactical surface metering capability. New strategic parameters such as Lead Time (i.e., the farthest time in advance that an SMP should be recommended), is currently set to 60 minutes; and Static Time Horizon (i.e., specified time to freeze TOBT in advance to help leverage surface metering for additional benefits) is currently set to fifteen minutes. Both are provided to help plan collaborative metering.

The web-based Surface Metering Display (SMD) shows the excess queue time plot and proposed metering programs within the lead time specified. The excess queue time plot is drawn from using metering threshold parameters set for each runway. The SMP menu provides user with entry options for rejecting or affirming/accepting an SMP, adjusting the SMP parameters, and potentially modifying an SMP recommendation. The TRACON, ATCT personnel and Ramp Manager collaborate to maintain and manage the SMPs. The SMD user interface notifies the user of the flight operator's consent for an SMP program and provides the notification of a request for an inter-flight operator and/or intra-flight operator substitution.

The SMP displays the following information:

- Status – current status of the SMP
- Runway – the runway for which metering will be needed
- Start – the predicted start time of metering
- End – the predicted end time of metering
- Flt Count – the predicted number of flights that will be assigned a gate hold
- Average Hold – the predicted average gate hold assigned to each flight
- Max Hold – the predicted maximum gate hold for a flight during metering

The possible states for current SMP status are:

- PROPOSED

The ATD-2 system is recommending metering and no user action has been taken.

- AFFIRMED

A user has affirmed the SMP or auto-affirm is enabled and the ATD-2 system is still predicting that metering will be needed.

- REJECTED



A user has rejected the SMP, but the ATD-2 system is still recommending it.

- ACTIVE

An affirmed SMP has started. Metering is now active for the runway.

- COMPLETED

An active SMP has ended or been terminated early by a user.

- OBSOLETE

The ATD-2 system is no longer recommending metering for this runway. Affirmed and rejected SMPs can become obsolete.

#### ***4.1.3.3 Inputs/Outputs***

The SMD user interface is expected to be as lightweight as possible in the ATD-2 architecture, given that is intended primarily as a user interface. Adaptation data will be required to allow the SMD to load statically adapted parameters which serve as defaults for the system (i.e., used in strategic and/or tactical scheduling).

In Figure 4.7, the data flow into and out of the SMD is shown from the standpoint of the producers and consumers of the data. Updates to important common situational awareness artifacts and scheduling inputs will be shared with the SMD as they happen, as shown by the data flow between the ARM and the SMP. The SMD will provide important updates to parameters and commands to the schedulers, as necessary to achieve the Surface CDM concept, as a prototype for TFDM and surface scheduling.

The surface scheduler will provide schedule output to the SMP for demand/capacity imbalance information purposes, as well as flight specific information for those flights for which a time was agreed upon by the users.

Data that may be useful for operational analysis, simulation input, and/or detailed system debugging purposes will be archived and disseminated to other users, as required.

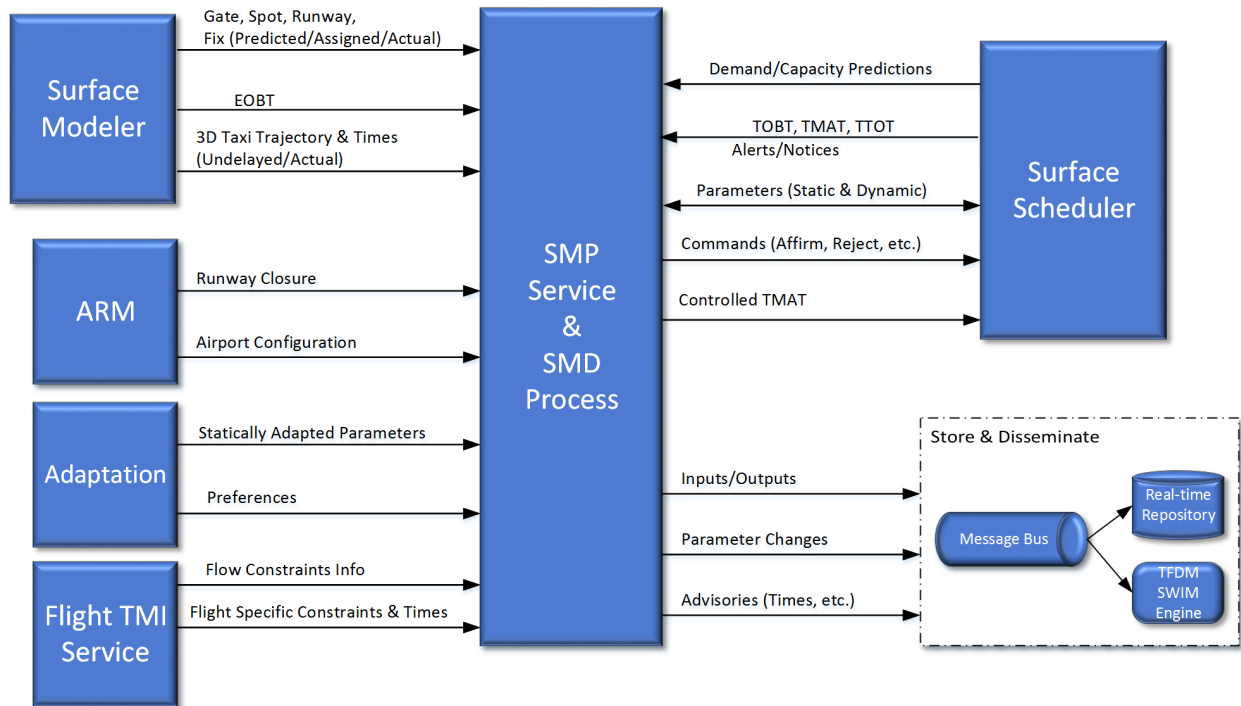

Figure 4.7 - The SMP user interface component consumes/produces a variety of data.

#### 4.1.4 TFDM/TTP SWIM

##### 4.1.4.1 Component General Description

The TFDM SWIM engine provides a prototype TFDM Terminal Publication (TTP) SWIM feed from the ATD-2 IADS system to external stakeholders, in a manner consistent with TFDM planning documents. The ATD-2 system will deliver information to flight operators and other consumers via the SWIM infrastructure. This component emulates the future TFDM SWIM data feed, so that effort invested by flight operators to interact with ATD-2 will be transferrable to the future FAA system. An additional goal is to help identify new TFDM SWIM data elements that are desired by the flight operators and are not currently specified in the TFDM Web Service Requirements Document (WSRD).<sup>9</sup>

##### 4.1.4.2 Functions

This component was designed using requirements in the TFDM Web Service Requirements Document (WSRD) as the baseline requirement source.<sup>9</sup> Discussions with the TFDM team that wrote the WSRD seem to indicate the expectation that all outgoing data would be in Flight Information Exchange Model (FIXM)/Aeronautical Information Exchange Model (AIXM) format. ATD-2 has recommended new data elements that should also help mitigate risk and mature this interface. Figure 4.8 shows the data flow in and out of TFDM SWIM engine within the ATD-2 system.

ATD-2 pioneered a way to daisy-chain (i.e., repeat) this data feed. This allows a number of distribution options for the production SWIM engine feed that would otherwise be difficult (e.g., run a repeated SWIM feed at William J. Hughes Technical Center (WJHTC), etc.), while also

allowing development systems to feed off operational data feeds with minimal impact to system performance.

An internal schema has been developed to simplify internal storage and processing of all the data elements used by ATD-2. This internal schema is a flattened version of the FIXM and AIXM based schemas specified in the TFDM WSRD, which also includes data elements not published to external consumers. Before data is published to consumers, the TFMD SWIM Engine maps the internal data elements to the TFDM schema and packages them into messages as specified by the TFDM WSRD. The benefit of using a non-standard schema internally is having a simple method of storing data elements in a database without complex nesting.

To convert data stored in the Fuser database into TFDM Terminal Publication (TTP) messages, the TFDM SWIM Engine listens for Flight Creation, Flight Update, and Flight Remove events from the Fuser via the Fuser Client API. Any of these events will trigger the flight data to be transformed to a FIXM or AIXM message, depending on the type of information. The TTP message is then published out to FAA SWIM. Populating the elements required by the TFDM specification for TTP Messages, the TFDM SWIM Engine either converts elements from the Fuser into the appropriate schema or calculates the value using the Metrics Service. The results from this conversion / calculation & derivation are stored in the TTP Data Base for future reference and debugging.

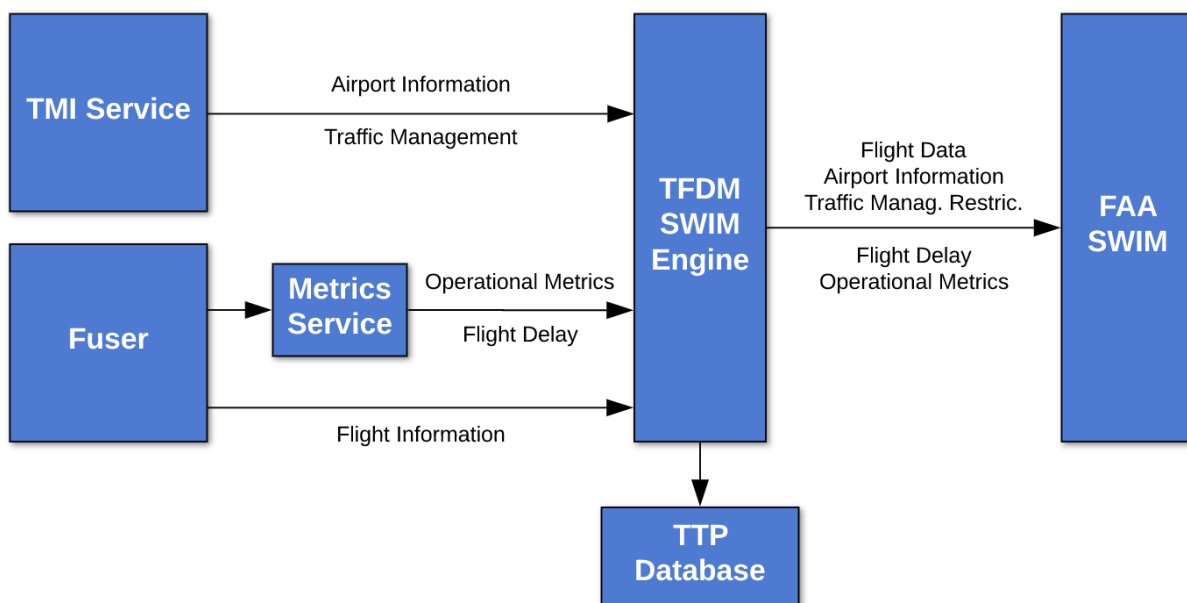

Figure 4.8 - TFDM SWIM Engine

#### 4.1.4.3 TTP SWIM Feed

ATD-2 uses the existing TFDM requirements to publish data to consumers and also make recommendations for new data elements as part of the technology transfer process so that the message sets may be extended. ATD-2 implemented five of the six information services defined in the TFDM WSRD. Table 4-2 below provides the list of TTP information services with an indication of the level of implementation reached on ATD-2. Due to the prototype nature of ATD-2, some of the information services were only partially implemented.

Table 4-2 - ATD-2 TTP Information Service Implementation

Information Service	Description	Implemented in ATD-2 TTP
Flight Data	Individual flight updates containing flight identifiers, targeted times, actual times, runway, parking gate, spot, departure fix (predicted, assigned, actual as appropriate), flight states, and more.	Yes
Airport Information	Airport configurations, airport and runway rates, ramp closures, runway closures, taxiway closures.	Yes (subset)
Traffic Management Restrictions	Call for Release programs departure MIT/MINIT restrictions, departure stop/ground stop programs. Along with list of impacted flights for each.	Yes (subset)
Flight Delay	Airport and runway delay by arrival, departure, and total.	Yes (subset)
Operational Metrics	Metrics on airport throughput and individual flight metrics.	Yes (subset)
Surface Metering Program	Parameters, notifications, and information related to the list of Surface Metering Programs for a TFDM airport	No

ATD-2 currently acts as a stand-in for TFDM before the FAA’s TFDM is implemented. ATD-2 is currently delivering information to flight operators and other consumers via the SWIM infrastructure. ATD-2 uses the existing TFDM requirements to publish data to consumers and also make recommendations for new data elements as part of the technical transfer process so that the message sets may be extended. At the time of this document’s publication, ATD-2 is producing data for CLT and DFW. ATD-2’s TFDM SWIM prototype is utilized by MITRE, AAL, Sensis, and Volpe. ATD-2 is working on a SWIM feed for DAL, and is working with Southwest to be the next consumer for TTP.

#### 4.1.5 Fuser

The Fuser processes and synthesizes inputs from disparate data sources to provide a consistent set of fused data to/from STBO. The Fuser incorporates flight matching across the data sources and assigns a Globally Unique Flight Identifier (GUFID) to each flight. It aggregates and mediates among all data sources to provide a coherent data set. Fused data is distributed to the rest of the IADS system and written to a PostgreSQL database to support analysis and debugging.

##### 4.1.5.1 Inputs/Outputs

This section introduces the high-level data flow to and from the Fuser system, as illustrated in Figure 4.9. NAS traffic flow data originates from external sources. These sources are shown on the left.

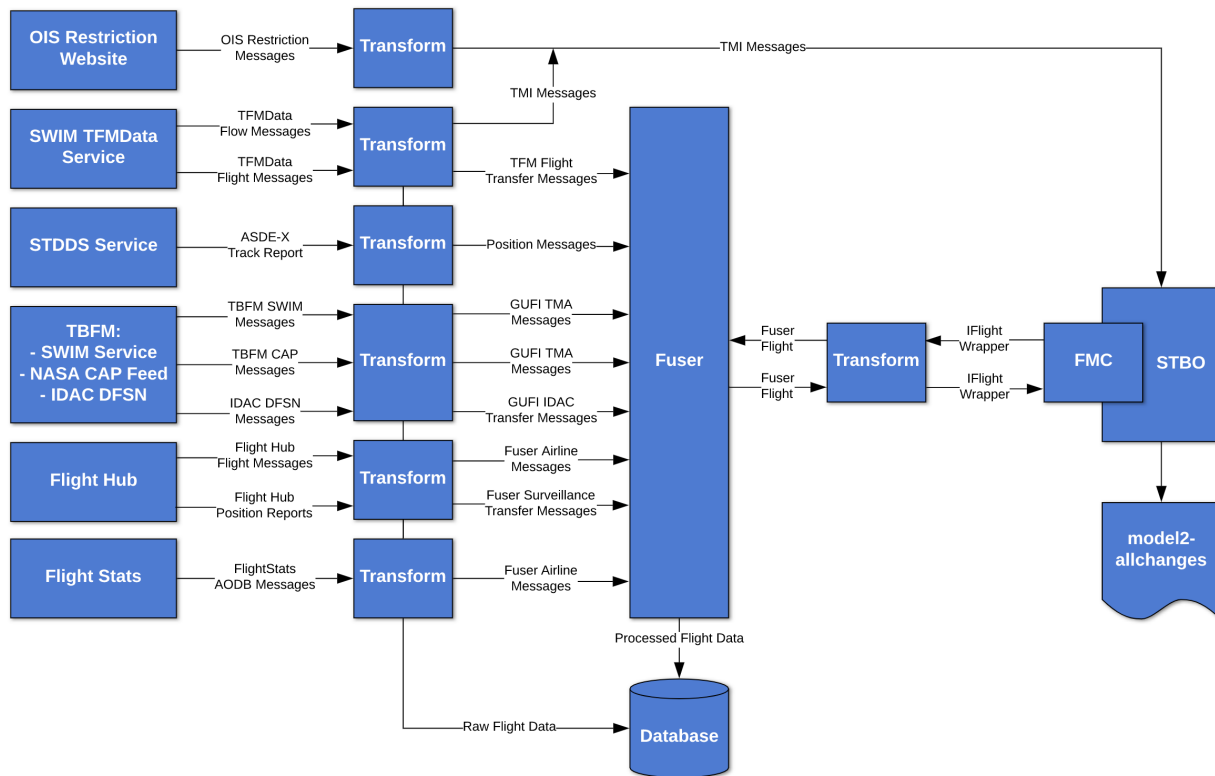

Figure 4.9 - This illustration shows the data flow to/from the Fuser.

The external interface data feeds include:

- Operational Information Service (OIS) website
- System Wide Information Management (SWIM) Traffic Flow Management Data (TFMDData) Service
- SWIM Terminal Data Distribution System (STDDS) Service (Airport Surface Detection Equipment – Model X (ASDE-X) track reports)
- SWIM Flight Data Publication Service (SFDPS), the FAA’s NextGen solution to provide users with access to real time National Airspace System (NAS) En Route information
- Three separate Time-Based Flow Management (TBFM) data sources:
  - SWIM TBFM Service
  - NASA TBFM Atlanta ARTCC (ZTL) Collaborative Arrival Planning (CAP) data feed
  - FAA TBFM Washington ARTCC (ZDC) Integrated Departure Arrival Capability (IDAC) Data Fusion (DFSN) data feed
- Flight Stats data files
- American Airlines (AAL) Flight Hub data service
- Advanced Electronic Flight System (AEFS), Runway assignment for departure flights

And as part of Phase 3 implementation the following data feed:

- Southwest Airlines data feed (for Dallas Love Field airport)

Each of these data sources represents flight or restriction data in different formats. The raw message formats are transformed into flight formats that the Fuser can more easily process. The Fuser then merges flight data from these different data sources into a common flight format.

The Fuser sends the common format flight updates to STBO via the Flight Management Connector (FMC). The FMC converts messages from the Fuser format to the receiving STBO component format and manages communications between the Fuser and STBO components and processes.

STBO components add additional information to the flight information, such as predicting the runway or taxi time, and updates from STBO components are sent back to the Fuser via the FMC. The Fuser updates the common Fuser flight data with the STBO component updates, along with any other updates the Fuser has received for the flight.

All Fuser data changes are processed, fused, and distributed, as well as written to the database. The Fuser database includes metadata to support data traceability for all flight modifications. The Fuser logs any flight changes it receives into its database. It also logs messages received from external data sources in separate tables. STBO logs any flight changes for which it is aware into a common data logging file.

#### ***4.1.5.2 Fuser System Components***

The Fuser system can be grouped into four types of sub-components, including the external interface processors, the database processors, the core Fuser components, and the Fuser STBO interface components. Figure 4.10 serves to illustrate the communication flow between the sub-components of the Fuser system and relevant external systems, primarily the external data interfaces and the other components of the STBO system. The external data interfaces include the actual external system data feeds, as well as the ATD-2 client components that connect to them.

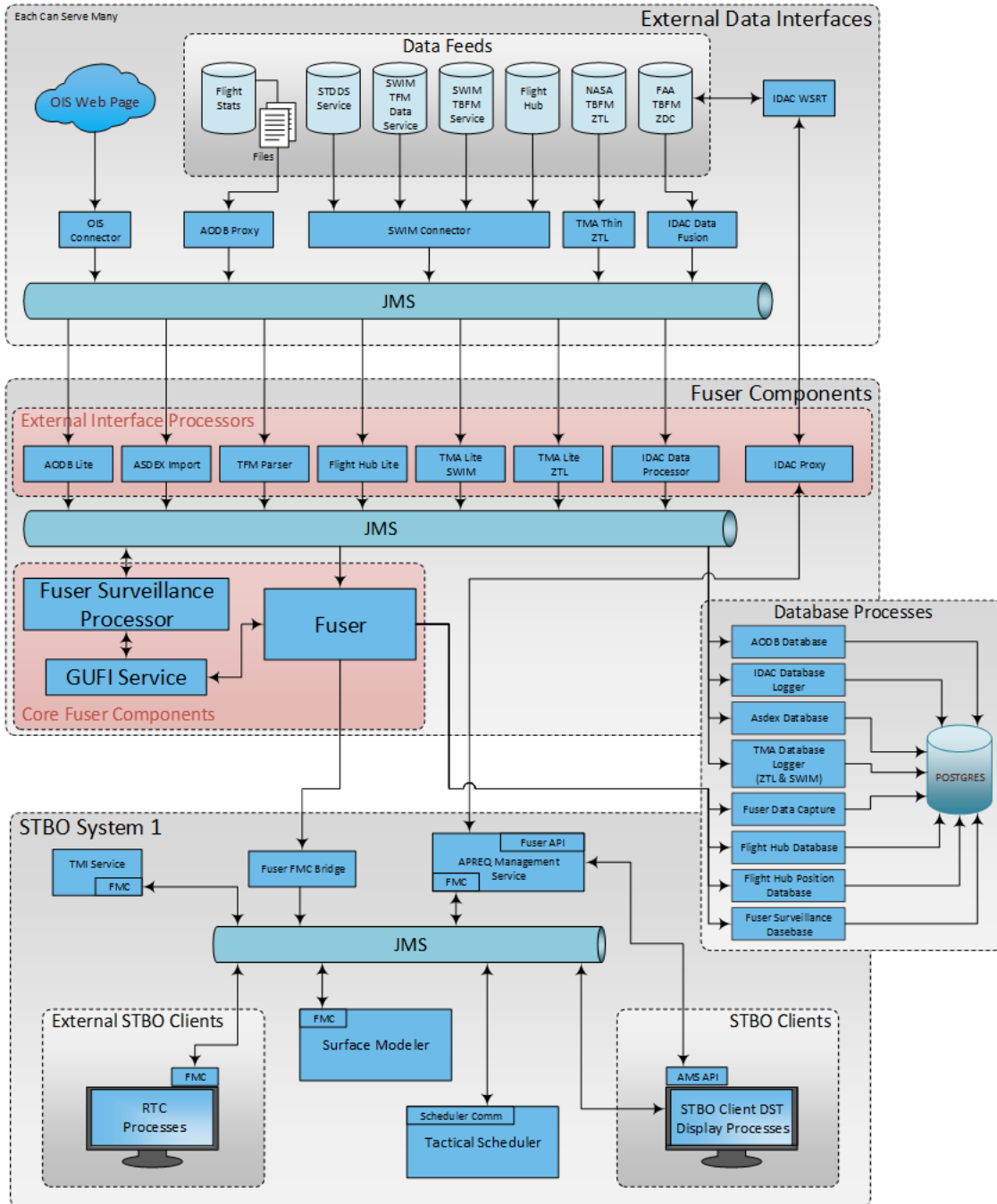

Figure 4.10 - The Fuser architecture overview shows the communication flow of the sub-components that comprise the Fuser system.

#### 4.1.5.2.1 Fuser external interface components

The external interface processors are responsible for interfacing the Fuser with the external data sources and are listed in Table 4-3 below. Typically, these processors transform data to a common format and publish to the Fuser. Several of these processors also handle GUFU assignment.

Table 4-3 - ATD-2 Fuser components are described in detail.

Component	Description
<a href="#">AodbLite</a>	Airlines Operational Database (AODB) Lite listens for AODB messages on a JMS topic as provided by the Flight Stats feed converted to AODB format. It expects to receive flight specific data from the flight operators. Each message is converted to a general use object structure and redistributed on a new topic to be picked up by the Fuser.
<a href="#">AsdexImport</a>	AsdexImport listens for ASDE-X messages on a JMS topic as provided by the STDDS data feed. It transforms messages to a common format, handles GUFIs assignment, and redistributes messages to the Fuser.
<a href="#">FlightHubLite</a>	FlightHubLite listens for FlightHub messages on a JMS topic as provided by the AAL Flight Hub data feed. It expects to receive flight specific and position messages. Each message is converted into a general use, non-AAL specific object structure and redistributed on new topics to be picked up by the Fuser.
<a href="#">IdacProcessor</a>	Processor that connects to the TBFM IDAC DFSN data feed, assigns a GUFIs, and passes data to the Fuser. The IDAC DFSN data feed is an internal TBFM messaging topic that has been made available to this effort.
<a href="#">IdacWsProxy</a>	Web service proxy for connection to the TBFM IDAC web services. The IdacWsProxy is used by the APREQ Management System to interface with TBFM.
<a href="#">TmaLite</a>	TmaLite listens for TBFM messages on a JMS topic as provided by either the TMA Collaborative Arrival Planning (CAP) feed or the SWIM TBFM service. It expects to receive flight specific and position messages. Each message is converted into a common format, assigned a GUFIs, and redistributed to the Fuser. The full Fuser system runs two separate instances of TmaLite, each connected to a separate TBFM system: NASA ZTL TBFM, and the TBFM SWIM feed.
<a href="#">TfmFlightXmlParser</a>	The TfmFlightXmlParser listens for “Flight” and “Flow” messages from the SWIM TFMDData feed. Flight messages are transformed to a common format, assigned a GUFIs, and published to the Fuser. Flow messages are transformed and published to the TMI Service. The TfmFlightXmlParser also stores the external messages to the database.
<a href="#">TfmTfdmProcessor</a>	Processor that connects to the TFMS Terminal Flight SWIM data feed and filters / flattens the schema in addition to retrieving the correct GUFIs from the GUFIs Service.

#### 4.1.5.2.2 Fuser database processor components

The Fuser database processors, listed in Table 4-4, were designed to record Fuser data to a PostgreSQL database. The recorded data includes raw data from external interfaces and data that is processed by the Fuser system. Note that some of the external interface processors and core Fuser components also serve database processing roles, if indicated in Table 4-3 and/or Table 4-5.



Table 4-4 - Fuser database processors record Fuser data to a PostgreSQL database.

Component	Description
<a href="#">AodbDatabase</a>	The AodbDatabase listens for AODB-formatted messages from the Flight Stats data feed and writes to the Fuser database.
<a href="#">AsdexDatabase</a>	The AodbDatabase listens for ASDE-X messages from the STDDS data feed and writes to the Fuser database.
<a href="#">FlightHubDatabase</a>	The FlightHubDatabase consumes FlightHub Flight messages from the AAL Flight Hub data feed and writes to the Fuser database.
<a href="#">FlightHubPositionDatabase</a>	The FlightHubPositionDatabase consumes FlightHub Position messages from the AAL Flight Hub data feed and writes to the Fuser database.
<a href="#">FuserDataCapture</a>	The FuserDataCapture consumes Fuser-produced messages and writes to the Fuser database.
<a href="#">FuserSurveillanceDatabase</a>	The <a href="#">FuserSurveillanceDatabase</a> listens for Fuser Surveillance messages from the FuserSurveillanceProcessor and writes to the Fuser database.
<a href="#">IdacDatabaseLogger</a>	The IdacDatabaseLogger logs all messages from the IdacProcessor to the Fuser database.
<a href="#">TmaDatabaseLogger</a>	TmaDatabaseLogger is a consumer of TMA messages from the TMA CAP and SWIM TBFM service data feeds. It writes messages to the Fuser database.

#### 4.1.5.2.3 Fuser core components

The core Fuser components, listed in Table 4-5 below, fuse data from the external interfaces into a common flight data format.

Table 4-5 - Fuser core components fuse data into a common format.

Component	Description
<a href="#">Fuser</a>	The Fuser component listens for incoming data from all of the external interface processor components. The Fuser transforms all data to a common schema, applies filtering and data mediation, merges to a current flight state, and sends the fused data to STBO.
<a href="#">FuserSurveillanceProcessor</a>	The FuserSurveillanceProcessor handles GUFU management for incoming messages on the Fuser Surveillance schema format and sends to the Fuser.
<a href="#">GufiService</a>	The GUFUService assigns and manages Globally Unique Flight Identifiers (GUFIs) for all Fuser components. The GUFU is the data element that is used for all flight matching by the Fuser, as there are several external flight data sources coming into the Fuser. This component also records all GUFU messages to the database.

#### 4.1.5.2.4 Fuser STBO interface components

Finally, the components in Table 4-6 serve as an interface between the STBO and Fuser systems.

Table 4-6 - Fuser STBO components serve as an interface between STBO and the Fuser system.

Component	Description
<a href="#">FuserFmcBridge</a>	The FuserFmcBridge passes data between the FuserClientApi and Flight Management Connector (FMC), which forwards the data on to other applications. The bridge takes Fuser Flight data from the Fuser, transforms it to FMC data using the FuserTransformServices, and passes it on to the Flight Management Connector (FMC) to be distributed to any listening applications. In reverse, the bridge takes FlightUpdates from FMC, transforms them to Fuser Flight format, and passes them to the Fuser for processing.

#### **4.1.6 Traffic Flow Data (TFD) Management**

##### **4.1.6.1 Component General Description**

The Traffic Flow Data (TFD) Management is a logical ATD-2 component that facilitates the data exchange of traffic information which is necessary to perform the Surface CDM operations, as defined in the future TFDM TFD process (section 3.2.2.2).<sup>6</sup> This capability is implemented in the ATD-2 architecture as the Flight TMI Service. For more information on the Flight TMI Service and the functionality that it provides, refer to section 4.1.10.

#### **4.1.7 Airport Resource Management (ARM)**

##### **4.1.7.1 Component General Description**

The Airport Resource Management (ARM) is a logical ATD-2 component functioning as a stand-in for the set of services that are envisioned in the future TFDM ARM process (reference TFDM specification, section 3.2.2.3) and in a sense a form of abstraction (meaning it is not a real component) for ATD-2. This capability includes a broad range of airport-related management functions, such as scheduling/updating the current and future airport configurations, setting/updating the runway and taxiway (for maintenance scheduling) and Ramp closures, assigning the default runways, balancing the runway loads, and setting/updating the airport resource status.

##### **4.1.7.2 Functions**

The ARM will generate and display the current and scheduled airport resource usage. It will generate and display the predicted runway schedule, to include flight specific data. The potential TFDM-ARM will allow a user to set the Airport Resource Capacity Rates (ARCR), but it is not clear how it will be displayed.

##### **4.1.7.3 Inputs/Outputs**

As shown in Figure 4.11, the ARM component has a number of inputs. Depending on whether the Center sets the airport arrival restrictions in TBFM, this value may be passed along and utilized by the surface system. However, some argue that this flow should be from the surface outward for TBFM purposes. The way in which TBFM uses this information for flow control, and the timing at which the configuration change takes effect, may be different between the

domains. Even if that's true, it is believed that this data will be useful for both planners and for common situational awareness.

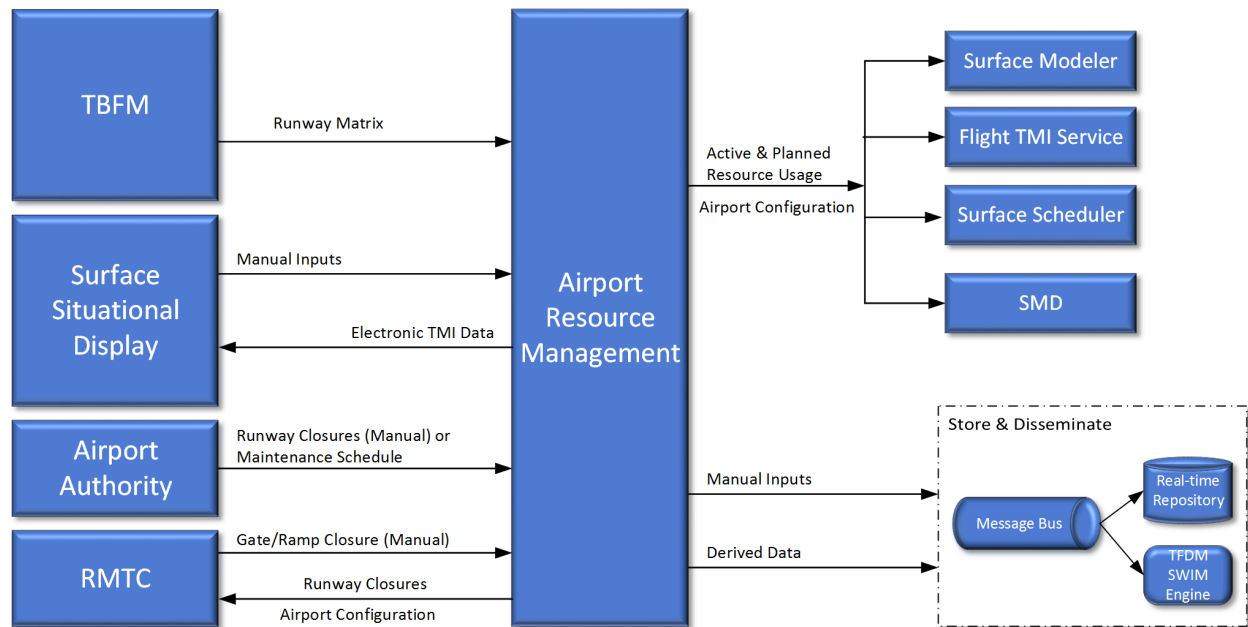

Figure 4.11 - The Airport Resource Management component consumes/produces a variety of data.

It appears that the TBFM runway separation matrix may be useful, as the site uses that to govern TBFM arrival metering flow. This data should be available from the operational TBFM SWIM feed, which is expected to be consolidated and filtered by the MP, and provided in the consolidated TMI feed.

Similar to the TFD component, the ARM component receives input from the Surface Situational Display. Functions will be provided to encourage load balancing, or use of a specific runway utilization strategy, by the TMCs in the ATCT tower and/or TRACON. These may not be automated, but they should make it easier for the controller to spot and remedy load balancing issues early, and thus encourage input.

It is envisioned that the airport authority will provide an electronic data feed of runway closure and/or maintenance information. If available, ramp closure information (potentially provided by the Ramp Manager and/or the airport authority) is also desirable for ARM. All outputs should be passed along to the SWIM engine and/or stored in a real-time repository.

#### 4.1.8 EFD/AEFS

##### 4.1.8.1 Component General Description

The Electronic Flight Data (EFD) component of ATD-2 maps to the EFD capability currently being used by the FAA as a replacement to paper flight strip processing in the ATCTs. The FAA committed to providing an EFD solution at CLT in support of the ATD-2 field demonstration, and elected to install the Advanced Electronic Flight Strip (AEFS) Prototype System, developed by the Terminal Second Level Engineering (TSLE) (AJM-24) at the FAA Tech Center. AEFS is operational code that has been in use at PHX, CLE, EWR, LAS, SFO, and was deployed to CLT

as part of the ATD-2 demonstration. It is considered to be an interim solution until the full TFDM system is deployed in couple of years (estimated 2021).

#### **4.1.8.2 Functions**

In support of the ATD-2 field evaluation, the FAA deployed the AEFS prototype to CLT to fulfill the EFD requirement. For Phase 1, AEFS and the ATD-2 IADS ran in parallel with manual data transfer between the systems. In the ATC Tower, the ATD-2 displays are only located at the Traffic Management Coordinator (TMC)'s desk. The TMC enters TMIs and other data from ATD-2 into the AEFS Traffic Manager (TM) display to share the info with the rest of the controllers at the tower including Clearance Delivery, Ground Control, and Local Control positions.

For Phase 2, an interface between AEFS and ATD-2 IADS was implemented to automate the data sharing. The goal of the Phase 2 AEFS-ATD-2 capability was to provide two-way real-time data exchange between the two systems to inform TFDM development. Data sent from ATD-2 are displayed on the flight strips for controller awareness, and runway assignments made in AEFS are sent to ATD-2 to update trajectory prediction and scheduler advisories. By integrating AEFS and ATD-2, all controllers are immediately updated when ATD-2 provides new TMI or other data – reducing the workload for the TMC.

The data sent from ATD-2 to AEFS include:

- Estimated, target, and actual ATD-2 times: EOBT, TOBT, AOBT, TMAT, Actual Movement Area entry Time (AMAT), TTOT (called ETD in AEFS)
- Assigned parking gate for departures
- APREQ: whether a departure is subject to an APREQ, the APREQ time when assigned, whether an APREQ is cleared, whether a flight is “Free Release”
- SWAP: whether a departure is affected by a Departure Fix Closure
- STOP: whether a departure is affected by a Ground Stop
- ONR (Operational Necessity Runway): whether a departure will be using a different runway due to Operational Necessity
- MIT: whether a departure is affected by a Miles-In-Trail restriction
- Arrival Gate Conflicts: list of arrivals with the flight status of On Final (getting ready to land) or ON (landed and taxiing to ramp), and the status of its parking gate (clear, gate conflict exists, or gate conflict is resolved)

The Phase 2 functionality mentioned above has been in operation since April of 2019.

The data sent from AEFS back to ATD-2 include:

- Runway assignment for departure: this informs ATD-2 that the departure flight will be using a different runway than our default prediction algorithm and allows the scheduler to make better advisories for that flight.

## **4.1.9 Surface Situational Display/STBO Client**

### **4.1.9.1 Component General Description**

The Surface Situational Display's user interface, also called the STBO Client, tracks the movement of aircraft on the runways and taxiways, and aircraft in flight that are on approach for landing. It provides convenience features that help the users attain better situational awareness. The user interface includes a map, flights table, timelines, notifications panel, and toolbar. The airport map shows the ramp, taxiways, and runways. The map can be zoomed out to view nearby airspace. The flights table contains detailed flight information, such as flight ID, aircraft type, date timeline for arrival and departure, destination, gate, spot, runway, departure fix, and TMI times, as well as many other surface scheduling parameters related to the flight. The timelines show arriving and/or departing flights on each runway, and the table can be customized per user's preference as to what features to be displayed. The notifications panel indicates user alerts.

### **4.1.9.2 Functions**

The Surface Situational Display shows the airport layout and the real-time traffic currently using the airport. It presents all the calculated, estimated, and target times, thus furthering development of the display requirements for the field. It also, displays departure fixes and the ability to visually distinguish traffic flow using color schemes.

All table, map, and timeline features can be customized. The flights table is customizable to display as much or little flight information detail as desired by users. Typical fields include flight ID, destination airport, aircraft type, flight status, gate, gate time, runway, runway time, departure fix, departure fix time, MIT, APREQ designation, EDCT time, and flight route. The ATD-2 functionality includes indication of Operational Necessity, cancelled flight, and Long On Board (LOB) awareness. The Operational Necessity functionality involves a runway change request made by either pilot or ramp for any operational reason for which the aircraft needs the longest runway for departure. The LOB functionality provides situational awareness to the ramp, ATCT, and TRACON concerning how long a departure flight has been on the surface since the door was closed, or how long an arrival flight has been on the ground without opening the door for the passengers to deplane.

The Surface Situational Display's user interface fully emulates the TBFM IDAC interface to enable users to request APREQ release times from TBFM and perform other tower-related functions. Symbology is added to STBO timeline elements to identify flights with APREQs and the status of their clearance request process. The APREQ/CFR or EDCT time is reverse-highlighted to show compliance (green for on time, yellow for early, and red for late). For flights subject to both APREQ and EDCT restrictions, the STBO timeline displays the options for both – green boxes for APREQ slots and a yellow rectangle for the EDCT compliance window. The APREQ and EDCT options may not always overlap, meaning that one of them needs to be re-negotiated with the Center and/or Command Center. Other timeline designations include display of Operational Necessity, MITs, Ground Stops, and closed departure fixes. Figure 4.12 is depicting a snapshot of the CLT surface situational display also known as the STBO Client.



Figure 4.12 - Elements of STBO Client Interface.

The notification panel informs users when important events occur. Notifications are displayed for runway utilization or flow direction changes, any fix/ramp/runway closures, and current TMIs, including MITs and Ground Stops. The Surface Situational Display will also notify users when an SMP is in effect and when the metering is active and/or inactive.

#### 4.1.9.3 Inputs/Outputs

Figure 4.13 depicts the inputs and outputs of the Surface Situational Display, or STBO Client. A broad range of traffic flow data management functions can be manually entered via the Surface Situational Display and distributed to other systems via Traffic Flow Data (section 4.1.6). Similarly, airport management configuration options can be set from the Surface Situational Display and distributed via ARM (section 4.1.7).

The Surface Situational Display allows users to add, update, or remove TMI restrictions. These changes are sent to the Flight TMI Service (section 4.1.10) for consolidation and distribution throughout the system.

The Surface Situational Display works with TBFM (section 4.3) to negotiate an APREQ slot. The IDAC interface shows the available overhead stream slots (green boxes) in the middle of the STBO timelines and allows Tower controllers to select a slot to request from the Center. The Center TMC receives an APREQ request notification in the TBFM TGUI and can approve, re-negotiate, or reject the requested slot. The Tower TMC then receives the response and takes the appropriate action. Manual entry of release times is possible for all APREQ aircraft. Swapping release times between APREQ flights in the same stream class is allowed.

All outputs from the Surface Situational Display should be passed along to the SWIM engine and/or stored in a real-time repository. In Phase 2 of ATD-2, it is envisioned that the Active SMP from the strategic scheduler will be displayed on the Surface Situational Display.

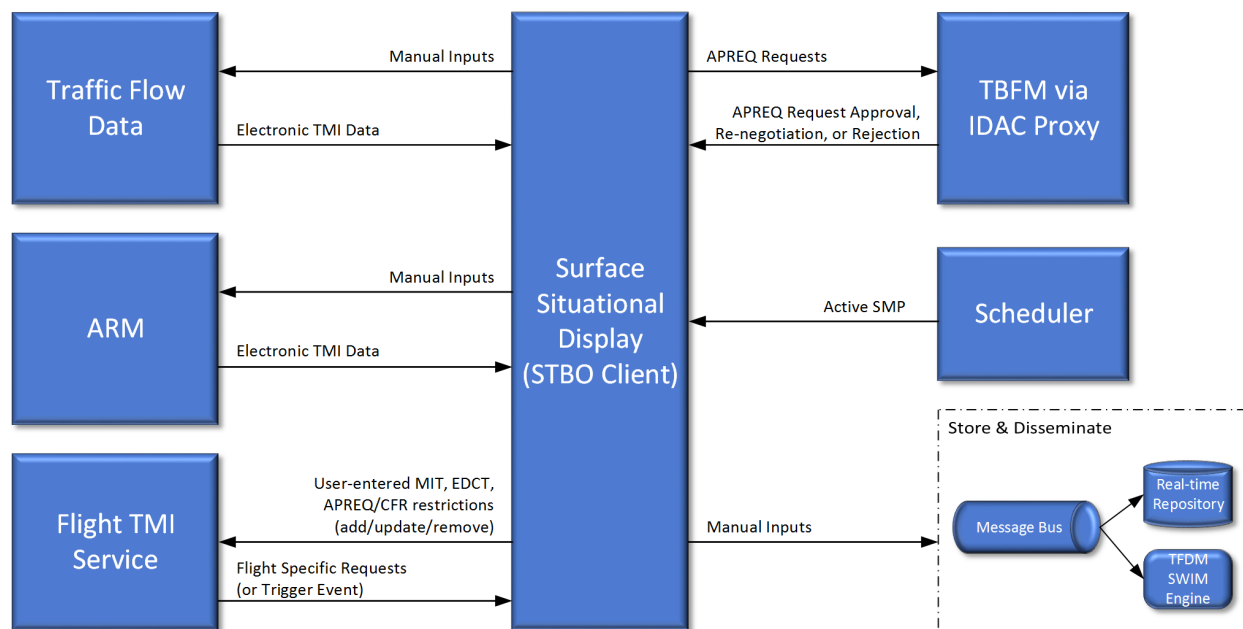

Figure 4.13 - The Surface Situational Display component consumes/produces a variety of data.

#### 4.1.10 Flight Traffic Management Initiative (TMI) Service

##### 4.1.10.1 Component General Description

The STBO Flight TMI Service consolidates the processing, management, and decisions related to all the flight specific TMIs for the STBO system. This logic is applied to flights subject to a wide range of TMI restrictions: APREQ/CFR, EDCT, MIT, Ground Stop, Ground Delay Program, etc. TMIs can be entered or obtained multiple ways: TFM Flow, Operational Information System (OIS), and manual entry by a user using either the STBO Client, and/or RMTC. The Flight TMI Service allows the logic for flight specific constraints to be consistent across the STBO system and reduces the complexity of other components that would otherwise need to implement their own TMI logic.

##### 4.1.10.2 Functions

The Flight TMI Service contains all the business logic needed for TMI management. It is the single authoritative source for how a TMI is handled, validating the TMI parameters and mitigating information that could be received from multiple sources (but does not de-conflict flights).

The Flight TMI Service processing constantly knows which TMIs apply to which flights that have already been issued, and the status of the flights' current compliance to the specific TMI. The TMI data is pushed to other components, available via request/response, or both. It applies the business logic in response to system events (e.g., new TMIs, modified TMIs, deleted TMIs, new flights added to system, flight modifications, etc.). It will also leverage changes to make



new/better decisions in terms of scheduler computation of new times. For instance, in the nominal case of a time being frozen with incomplete information (e.g., due to system timing issues an EDCT was set without yet knowing about a TMI), but which later required an update due to a system event, an opportunity for a better time was provided which now includes multiple constraints.

#### 4.1.10.3 Inputs/Outputs

The Flight TMI service receives TMI information from TFM – Flow, OIS and user inputs, identifies which flights are affected by a TMI, and associates the flight to the TMI. When any flights are created or updated, or restrictions are added, updated, or removed, the Flight TMI Service compares the flight to the current restrictions in the system. If the restriction is applicable for the flight (based upon matching resources, flight times between restriction start/end time, and constraints), the restriction ID is added to the flight's list of restrictions. If TMIs include specific constraints (inclusions or exclusions), the constraints are transformed to filters in the Flight TMI Service to be used during assignment of restrictions to flights. It also translates the MIT into a “time slot” for each impacted flight, and then adds the TMI information to the flight’s data and distributes it to the other components. TMIs can be removed either manually from the TMI service by a user, and can be removed from the source (e.g. OIS) or automatically by the Flight TMI Service when it has expired. Table 4-7 below lists the Flight TMI Service, TMI Types and sources.

Table 4-7 - Flight TMI Service - TMI Types and Sources

<b>TMI Name</b>	<b>Source</b>
<b>Airport Configuration</b>	STBO Client
<b>APREQ</b>	OIS, STBO Client
<b>Fix Closure</b>	OIS, STBO Client
<b>Ground Stop</b>	TFM-Flow, STBO Client
<b>MIT</b>	OIS Connector, STBO Client
<b>Ramp Closure</b>	RTC Client
<b>Runway Closure</b>	STBO Client
<b>Metering Mode</b>	SMD Client
<b>EDCT</b>	TFM-Flow, STBO Client
<b>Ground Delay Program</b>	TFM-Flow, STBO Client

As TMIs are received, they are examined to determine if they match a TMI already in the system. Criteria for determining a match includes start time, entity key, and data specific to each TMI type. If the incoming TMI does not match any current TMIs already in the system, a new ID is generated and added to the TMI. Then it is added to the TMI Service, stored in the TMI database for recovery purposes (if enabled), and distributed back out to any listening components.



It is expected that incoming TMIs have an action of either PROPOSE\_ADD, PROPOSE\_UPDATE, or PROPOSE\_REMOVE. This is to indicate that the TMI has not yet been processed by the TMI Service, but simply has been sent to the Flight TMI Service for processing. Once the Flight TMI Service has processed the message, it will be distributed with the corresponding action (ADD, UPDATE, REMOVE) to be handled by each individual listening component. If a TMI is received with a non-propose action (ADD, UPDATE, REMOVE), it is still processed and added to the Flight TMI Service; however, it is not re-distributed via the Fuser. This is because the listening components will process any TMIs with those action types. Ideally, those actions will only be distributed by the Flight TMI Service after processing; however, if a TMI is somehow sent from another component with a non-propose action, the Flight TMI Service will not re-distribute the TMIs in order to prevent duplication in other components.

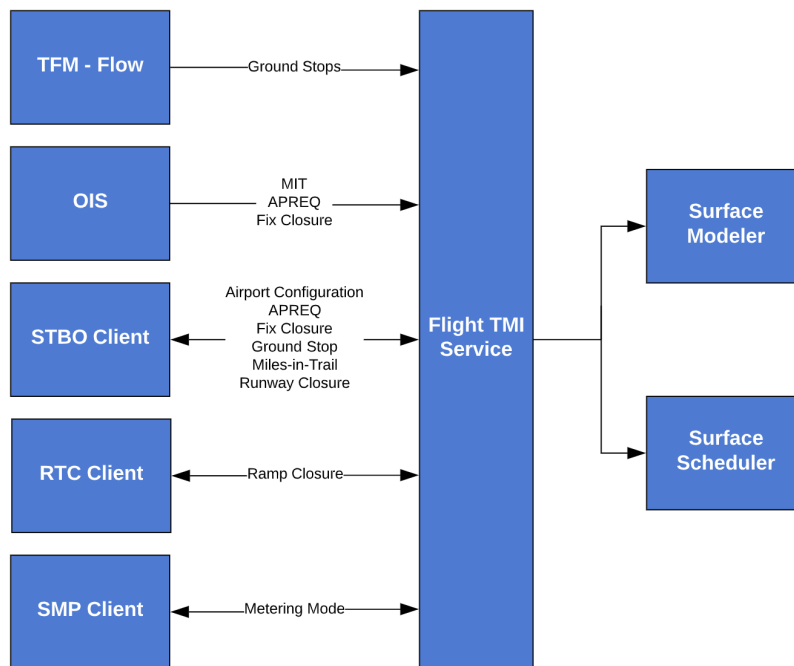

Figure 4.14 - TMI Service - Inputs/Outputs

Several of the TMIs accepted in the STBO system are considered specific to flights, meaning it will apply to some flights, but not others. For example, a fix closure for BARMY is applicable for any flights using that fix, but will not apply to flights using another fix. Other TMIs are applicable for the airport in the current system (i.e., ramp closures are looked at by RTC to display when a ramp is closed, but the modeling does not currently look at ramp closures to automatically change flight information for the assigned ramp). The Flight TMI Service determines which flights are impacted and updates the Surface Modeler, Strategic Scheduler, and Tactical Scheduler, accordingly.

#### **4.1.10.4 TMI Evolution**

APREQ Swaps and One Click Reschedule have both improved the efficiency of the ATC Operators at CLT. These features, along with pre-scheduling of APREQs with ZTL, overall scheduler improvements, and integration with AEFS, have significantly improved APREQ compliance with both ZTL and ZDC over the past year. Other improvements include identifying to the user the sources of the restrictions in the TMI panel and the “Free Release” capability. In addition, a large time savings and timely information sharing with the controllers (through AEFS), ramp (through RTC/RMTC), and the ARTCC/Tower/TRACON (through STBO) has occurred without the need for verbal communication in passing various TMIs such as GS's, SWAP's, EDCT's, and MIT.

The TMI Processor receives and manages the TFMS and OIS/NTML data from the Fuser and user input data from the STBO GUI. It also integrates with the FMC Process to send IDAC-like messages to TBFM to request and receive acknowledgement of controlled release times.

TMI Evolution was intended to investigate adding more capability to the IDAC-like APREQ processing at CLT consistent with TFDm requirements, working towards a goal of “automatic release” for APREQ flights. This was to improve operator efficiency as well as improve APREQ compliance. It had a goal to reduce the perceived duplication and latency from TMIs received from external sources (OIS and NTML), if possible, and to increase the types of TMI data being received from TFMS/SWIM.

While many improvements in compliance and efficiency have been realized, the goals of automatic release and improvement in receipt of external TMIs from OIS and NTML have yet to be achieved.

#### **4.2 Metroplex Planner (MP)**

The Metroplex Planner (MP) is a Phase 3 consideration.

#### **4.3 Time Based Flow Management**

NASA’s original field demonstration plan envisioned deploying NASA-modified TBFM systems to run in parallel with the operational TBFM systems at Washington ARTCC (ZDC) and Atlanta ARTCC (ZTL). However, the parallel deployment introduced undesirable complexities for ZDC and ZTL traffic managers. NASA collaborated with the FAA (led by NextGen and the TBFM program office) and the TBFM development contractor (Leidos, formerly Lockheed Martin), to develop a “minimally disruptive” solution for TBFM aspects of the ATD-2 field demonstration. This solution involves implementing an interface between the IADS surface component (i.e., STBO) and the operational TBFM systems at ZDC and ZTL. This section provides an overview of the STBO-to-TBFM interface. Additional details may be found in the Lockheed Martin design document.<sup>10</sup>

The version of TBFM utilized was standard TBFM v4.6 with only minimal changes (e.g., adaptation files, security certificate, etc.) to interface with the IADS STBO subsystem. Figure 4.15 shows NASA’s Super Integrated Departure Scheduling Tool (Super I) solution for interfacing IADS with an operational TBFM system.

As-is: TBFM 4.4.1 Tower & TBFM Back End System Interaction



To-Be: ATD-2 Proposed Interaction with TBFM 4.6

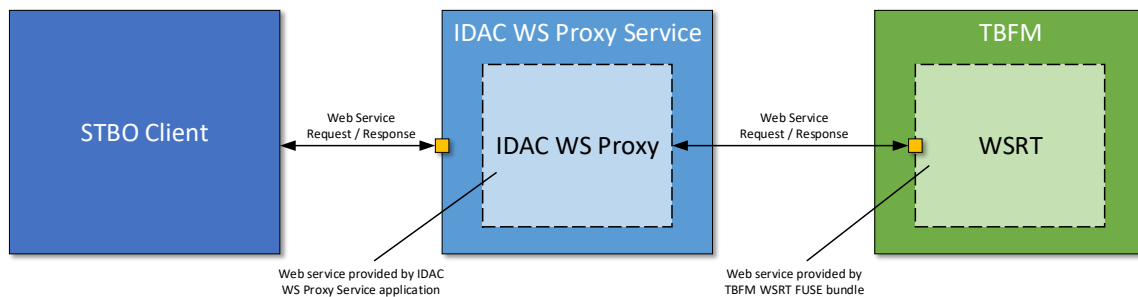

Figure 4.15 – The current TBFM Tower and back end system interaction is contrasted with the “Super IDST” solution proposed by NASA.

The top portion of the figure represents a standard operational TBFM Integrated Departure Arrival Capability (TBFM/IDAC) installation wherein an I user interface located in the ATCT is used by a TMC to perform tactical departure scheduling operations with the Center’s TBFM system. NASA has created an IDAC Web Services (WS) Proxy that allows the IADS STBO system to interact with the operational TBFM via its Web Services Routing Tool (WSRT), which brings out essentially the same functionality as the human-operated I. The solution is depicted at the bottom of Figure 4.15.

The ATD-2 team developed a prototype of the IDAC WS Proxy and successfully tested it with TBFM v4.6.0. The IDAC WS Proxy provides the following benefits to the ATD-2 field demonstration:

- The WSRT web services are designed to be used by the IDAC user interface
- Using the WS Proxy simplifies what the STBO components need to know
- Prevents STBO from needing to know about the configuration of IDAC
- It allows for mocked-up testing

- It isolates STBO from possible changes to the WSRT

The IADS-to-TBFM communications depicted in Figure 4. are summarized from the Lockheed Martin design document<sup>10</sup> in the sections below.

#### ***4.3.1 Information Flow from TBFM to IADS***

The IADS system requires knowledge of all departure Jet flights known to the TBFM system that are potentially subject to IDAC scheduling. Since TBFM only sends to its I today the flights currently subject to IDAC scheduling, this requirement will result in the need for a larger data set of flights than what is currently relayed to the TBFM I. The published flight stream also includes the following information:

Scheduling time and state information

Constraint and Constraint Satisfaction Point (CSP) assignment information

Identifier/owning facility information necessary for IADS requests to TBFM to be accepted

General metering constraint information

Additional operational data of interest includes a pre-packaged data set known as Reconstitution data. This data, provided upon request, includes the most up-to-date Flight Data, Airport Configuration, Adaptation and Playback information.

#### ***4.3.2 Information Flow from IADS to TBFM***

During ATD-2 testing, the IADS system emulate IDAC's Integrated Departure Scheduling Tool (I) input capabilities for flights. TBFM uses its existing capability to accept and implement these requests. Two types of inputs have been provided that include the following information:

Regular, automatic updates of coordination times and Departure Configuration updates

Irregular, manual updates of available space, departure negotiation, and departure swap requests, along with departure airport configuration updates

Figure 4.16 shows the relationships between FAA and NASA systems in the IADS prototype system as proposed for the ATD-2 field demonstration. The dashed line separates FAA equipment and NASA equipment. The FAA systems are shown in orange, while NASA systems are shown in blue. Note that there are four TBFM systems depicted in this figure. The two on the left are the FAA's operational TBFM instances at ZDC and ZTL. The two TBFM instances on the right are NASA-modified, TBFM software running on NASA equipment. These two NASA-modified TBFM instances are used to provide data to the IADS STBO subsystem and have no connection with or impact on FAA systems. This arrangement ensures that communications between the IADS STBO subsystem and the FAA TBFM systems at ZDC and ZTL are limited to just those messages necessary to perform tactical departure scheduling.

Note also that the IDAC Proxy described above is depicted below the STBO box, communicating with the FAA TBFM systems via a firewalled connection. Essentially, the ATD-2 STBO system is acting as a stand-in for a future TFDM system. NASA believes that the TBFM/IDAC I user interfaces will eventually be deprecated in favor of TFDM at appropriately equipped towers. A virtue of this proposed solution is that ATD-2 can serve as a pathfinder for this interaction between TBFM and TFDM.

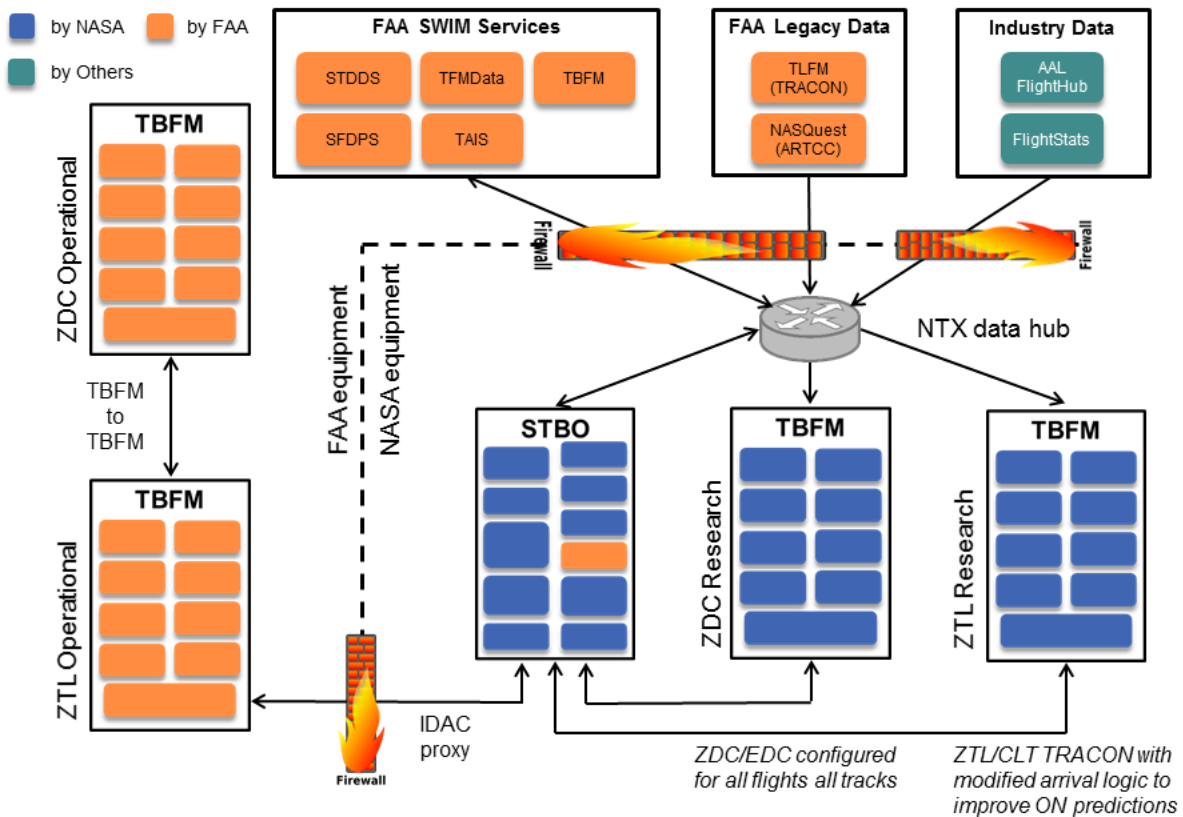

Figure 4.16 - The relationship among the TBFM and STBO systems is shown in the NASA proposed solution.

Figure 4.17 illustrates the solution pursued by Lockheed Martin/Leidos, as presented in a TBFM Integration Systems Issues Group (SIG) study.<sup>11</sup> The right side of this figure shows two operational TBFM instances. ZDC is at the top and ZTL is at the bottom. The left side of the figure depicts the ATD-2 STBO system running at CLT, along with the IDAC Proxy described above. This approach envisioned the ATD-2 STBO communication with the ZDC TBFM system being routed via the ZTL TBFM system, using the TBFM-to-TBFM (T2T) capability.

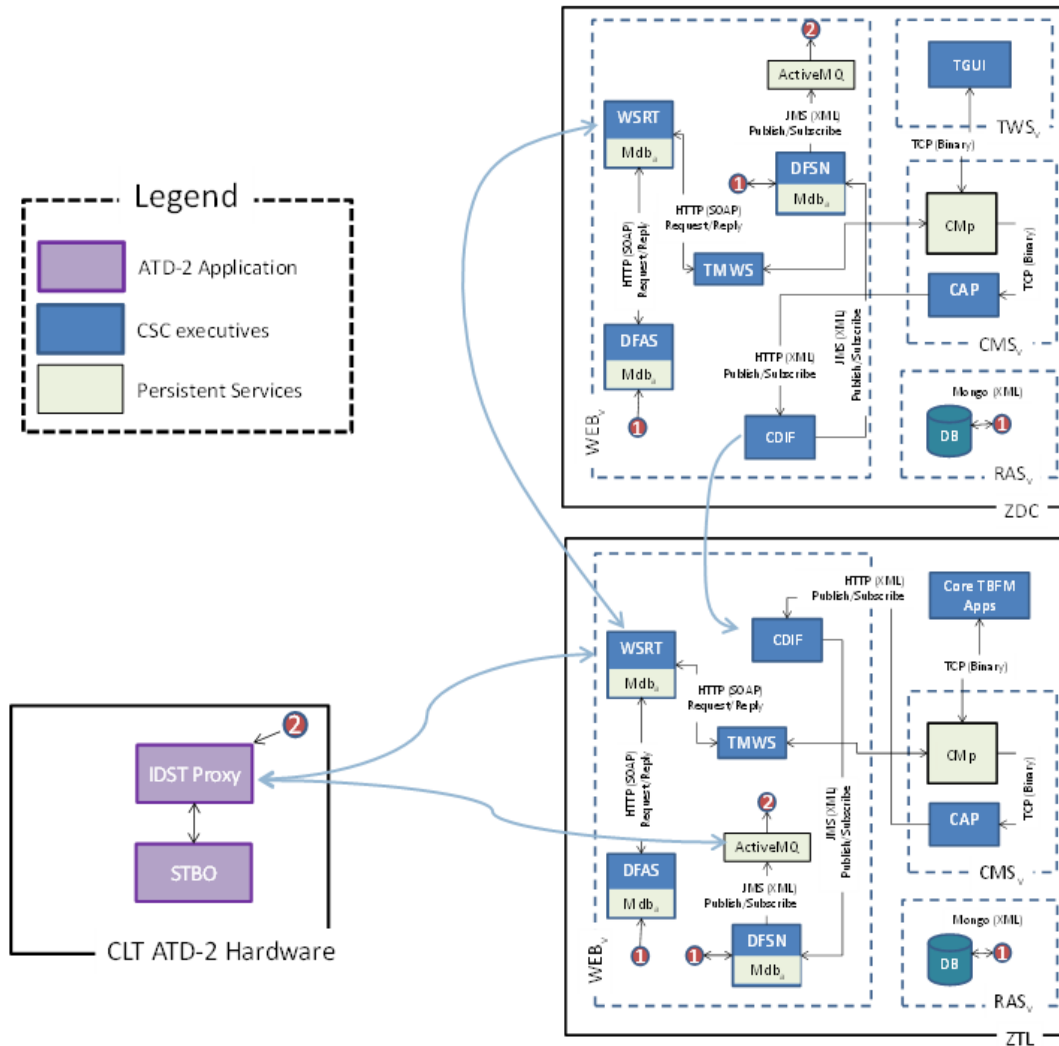

Figure 4.17 - Lockheed Martin proposes a solution leveraging TBFM-to-TBFM capability.

#### 4.4 IADS Ramp User Interfaces

For the ATD-2 field evaluations, NASA has provided IADS ramp user interfaces for the flight operators (Ramp Controllers). The RTC and the RMTC play a key role in supporting the IADS data exchange and integration capability that is foundational to data sharing across domains, agencies, and viewpoints. The RTC/RMTC is comprised of an interactive map display, “electronic flight strip”, and flight icons that reflect user inputs and flight state information. They provide common situational awareness and decision support functionality for the ramp controllers and the ramp managers – with capabilities such as the display of flight movement in the ramp and taxiways and surface metering advisories. It provides live data for all flights including Earliest Off-Block Times (EOBT) and Traffic Management Initiatives (TMI). The RTC augments management of ramp traffic by providing notifications of runway configurations, and it lists flight arrivals, near arrivals, and departures as additional sources of information. In the end state, these user interfaces are envisioned to be part of a flight operator system.

The RTC and the RMTC are map display interfaces that consist of a status bar and an airport surface map with surveillance data. They provide a visual representation of current aircraft positions in the ramp, Airport Movement Area (AMA), and near airspace. The status bar indicates the current airport configuration/runway utilization intent, the ramp status, and the metering mode. It also has a notification area where alerts are displayed. The map displays flight tracks with detailed flight information including the flight ID, aircraft type, gate, spot, runway, current flight ownership (ramp sector or Tower), and scratchpad. Departure flights also display the departure fix, TMI times (if any), and the scheduled pushback time. The scratchpad field is used to enter information, such as critical flight designations, to be shared with other ramp controllers. The maps can be zoomed in to view a specific sector of the ramp or zoomed out to view the entire airport surface. Figure 4.18 shows a snapshot of the CLT RTC.

There are many data exchange elements shared between the Ramp (RTC/RMTC) and the Surface Trajectory Based Operations Client (used in ATCT), including Traffic Management Initiative (TMI) information, notifications, ramp status, airport configuration, and closure information. For example, taxiway links are displayed in red on the RTC/RMTC map if they have been marked as closed in the STBO Client.

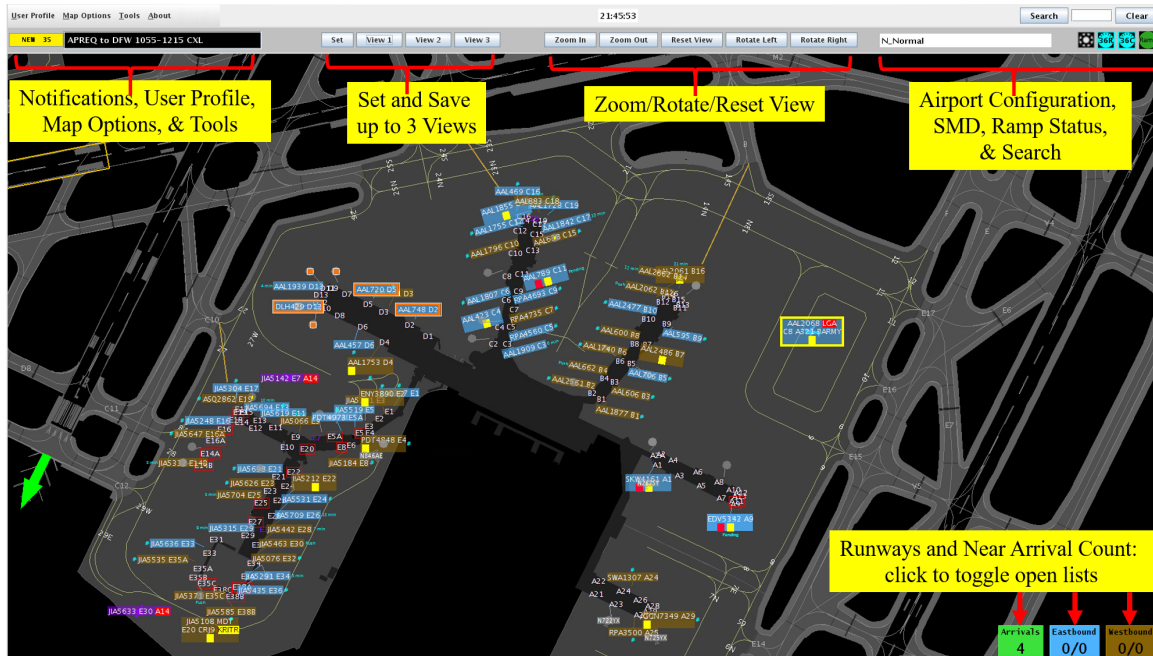

Figure 4.18 - RTC Interactive Map Display.

#### 4.5 Mobile App/Short Message Service (SMS) Texting

EOBTs are an important piece of scheduling information which the ATD-2 IADS Surface Scheduler uses to accurately predict runway demand and surface schedules.

At Charlotte’s main Ramp, the commercial airlines compute EOBTs for each of their flights by tracking the progress of pre-departure tasks (e.g., passenger boarding, baggage loading). Airlines then share these EOBTs with the Surface Scheduler. As the flight nears its departure time, the EOBT prediction becomes more accurate.

In contrast to commercial operations at the main Ramp, General Aviation (GA)/Business Aviation (BA) operations do not have the same mechanism by which to obtain accurate, real-time EOBTs for each flight. That is, there is no airline to monitor pre-departure progress and provide the Surface Scheduler with EOBT predictions. Also, the actual departure time in GA/BA operations can vary considerably from the filed departure time. In Corporate BA operations, for example, uncertainty in passenger arrival time can lead to uncertainty in departure time. Because the Surface Scheduler relies on accurate schedule inputs for generating traffic demand predictions, the filed departure time alone does not sufficiently support the Scheduler. While GA/BA flights account for about 6 percent of all operations at CLT, receiving accurate EOBTs from GA/BA pilots could potentially have a greater impact on the accuracy of traffic demand prediction at airports with a larger proportion of GA/BA operations.

The Mobile Application (App)/SMS Texting Capability technology provides a mechanism by which to obtain an accurate ready-time (EOBT) directly from the GA/BA pilot, which can then be passed to the Surface Scheduler. Instead of relying on the departure time filed as part of the original GA/BA flight plan, the Surface Scheduler can take advantage of receiving real-time, accurate EOBTs from GA/BA flights to generate a more accurate prediction of runway demand and surface schedules.

The MITRE Corporation has developed the Mobile App and SMS Texting Capability prototype tools and began a beta-test with a small group of BA pilots in October 2017 at CLT. This work is led by the FAA's NextGen (ANG) program office, in collaboration with NASA's ATD-2 Project team.

The Mobile App/SMS Texting Capability allows the GA/BA pilot to submit a ready-time (EOBT) for their flight, as well as update the EOBT when necessary. The EOBTs from GA/BA flights enable the Surface Scheduler to generate a more accurate prediction of runway demand and overall airport schedule. The airport as a whole, including commercial operations, can benefit from more accurate runway demand predictions.

When a pilot submits a ready-time (EOBT), via the Mobile App or SMS Text Capability, it is transmitted to MITRE's backend server. That server: 1) sends an acknowledgement back to the user to confirm the EOBT has been received, and 2) sends the EOBT to the ATD-2 IADS system at CLT, via the TFDN Terminal Publication (TTP) data feed which NASA publishes on the SWIM research and development network.

Two-Way Information Exchange between the beta-test pilots at CLT and the ATD-2 system was enabled in November 2018. When the ATD-2 IADS system at CLT receives an EOBT, it generates flight-specific schedule and planning information for that flight. Selected data elements (i.e., predicted runway assignment, expected Target Takeoff Time (TTOT), and APREQ status) are passed back to MITRE's backend server, via the TTP feed. Their server then sends those data elements to the pilot via the Mobile App or SMS Text Capability.

The same process is repeated if the GA/BA pilot submits a revised ready-time (EOBT).

Initially, MITRE developed a prototype Mobile App, "Taxi Time", which was available on "TestFlight", Apple's beta-test platform and required an iPhone. Through user feedback, the MITRE team discovered that beta-test participants felt that the App added an extra step to their pre-departure workflow, making it easy to forget to submit a ready-time (EOBT) for their flight.



Corporate BA pilots explained that while one pilot waits in the Fixed Base Operator (FBO) building for passengers to arrive, the other pilot stays on the Flight Deck and they communicate via text.

In response to that feedback, MITRE developed a prototype SMS Texting Capability which allows pilots to submit their ready-time (EOBT) and receive flight-specific information in return, via text, without having to open and navigate through an App. Other advantages to using text, instead of an App, are that participation does not require an iPhone, or even a smartphone, and that users are not required to install an App, which was prohibitive to some Corporate BA pilots using company-owned cell phones.

#### **4.6 Real-time Dashboard**

The real-time Data Analysis and System Health (DASH) dashboard tool and application is part of the ATD-2 system with a web-based application display, independent of the STBO Client, that enables users to view metrics across airport operations. The real-time dashboard was made available as a part of each operationally deployed system to CLT and has been providing key metrics to a variety of users within the FAA, the flight operators, the CLT airport facilities, and the ZDC and ZTL Center TMU. The dashboard was developed to provide insight into capacity, efficiency, and predictability, as well as the effectiveness of scheduling and metering. This capability also enables detailed displays of metrics, both numerically and graphically, along with features that enable electronic reporting of issues.

Current capabilities of the real-time dashboard application include a quick-look panel reporting TMI events applicable to the airport, such as APREQs, MITs, Ground Stops, and Departure Fix Closures. Numerous plots provide an in-depth analysis of metrics, such as departure and arrival monitoring, predicted excess queue time, taxi status, arrival/departure rate, and throughput. A “quick” analysis of these metrics is also provided on the quick-look panel.

The DASH toolbar by itself displays the current time along with a set of icons that provide information regarding current runway utilization, ramp status, and metering mode. A Monitors button is also provided on the DASH to access a menu of available Monitors. The runway utilization, ramp status, and metering mode icons displayed on DASH are the same icons shown on the STBO Client toolbar as well as on the RTC and RMTC upper status bar.

It should be noted that the Data Analysis and System Health (DASH) toolbar and its monitoring features were implemented at CLT and used frequently as part of Phase 1 and the early days of Phase 2, but now is not as heavily used and in some respects, many of its features have been implemented into the SMP portion of the IADS system.

## 5 Interface View of ATD-2

This section provides an overview of the physical interfaces of the IADS system prototype as it is being implemented for the ATD-2 field demonstration. NASA, the FAA NextGen Organization, and the FAA Communications, Information, and Network Programs (CINP) Team developed this material as part of an Enterprise Infrastructure Services (EIS) Assessment of the ATD-2 field demonstration prototype system.<sup>12</sup>

NASA's information systems security plan for ATD-2 employs an abstraction known as the NextGen Emulation System (NEXUS) to define information system boundaries and two types of interfaces: User Interfaces (UI) and Data Interfaces (DI). Figure 5.1 is a geographic depiction of the various NASA installations involved in the ATD-2 field demonstration. ATD-2 IADS system interfaces are listed for each of the installations, and classified as either UI or DI interfaces according to the NEXUS definitions in Appendix: Security, NEXUS, and Interfaces.

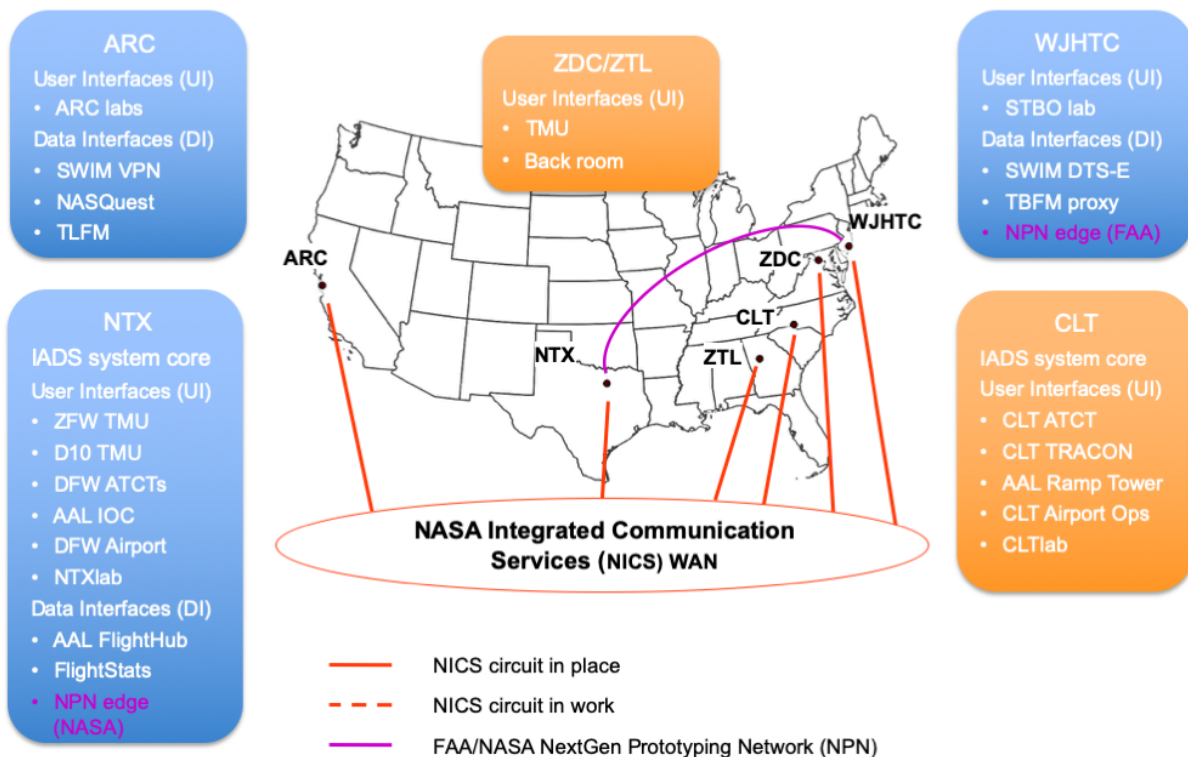

Figure 5.1 - This geographic depiction shows the locations of the NASA installations that will support the ATD-2 field demonstration.

### 5.1 Network infrastructure

The NASA installations shown in Figure 5.1 are served by two different wide area networks (WANs): NICS and NASA/FAA's Private Network (NPN). The NICS WAN (shown in red) is named for the NASA Integrated Communications Services contract, which provides networking and other communications services throughout the agency. NICS is overseen by NASA's Communications Services Office (CSO). The NPN WAN (shown in purple) is part of the FAA's NextGen Prototyping Network, which provides secure, high-bandwidth connectivity for

NextGen Test Bed facilities.<sup>13</sup> The NPN is the primary link between NASA and FAA information systems for ATD-2, with the interconnection point located at NTX.

## 5.2 NASA Ames Research Center (ARC)

**General:** Located at Moffett Field, CA, ARC is one of about 10 NASA research and space flight centers. ARC is the home base for the ATD-2 research and development team and is the focal point for simulation experiments, software development, Verification and Validation (V&V), testing, and data analysis for ATD-2. ARC has a limited role in supporting daily use of the ATD-2 IADS prototype system in the field.

**Data Interfaces (DI):** The NASQuest and TBFM TRACON Live Feed Manager (TLFM) data feeds are currently delivered from WJHTC to an FAA-managed server at ARC. A SWIM Internet VPN feed to ARC serves as the tertiary SWIM data feed for ATD-2.

**User Interfaces (UI):** Located in various labs for IADS prototype development, system monitoring and technical support.

## 5.3 NASA North Texas Research Station (NTX)

**General:** NTX is a NASA laboratory on the premises of FAA Fort Worth ARTCC (ZFW) in Fort Worth, TX with research systems embedded in various operational facilities in and around Dallas/Fort Worth International Airport (DFW) including: ZFW, DFW TRACON (D10), DFW ATCTs, DFW Airport, DAL airport and American Airlines (AAL) Integrated Operations Center (IOC) facility, as well as Southwest Airline Network Operations Center (NOC). The ATD-2 field demo team is based out of NTX, and the IADS prototype system data hub and other key back-end processes are housed at NTX. As noted above, NTX is the interconnection point between the NPN and NICS WANs.

**Data Interfaces (DI):** All NASA/FAA data connections routed through the NPN may be thought of as having DIs at NTX, since it is the NASA end-point for the NPN. However, the DIs are physically implemented via NASA-managed servers located at WJHTC. NTX also hosts DIs for the AAL FlightHub data feed, and the commercial FlightStats data service as well as MITRE mobile app., and Southwest Airline flight data. Finally, an Internet VPN SWIM connection to the Oklahoma City (OEX) NESG has been established to NTX to serve as a backup to the DTS-E SWIM connection delivered via the NPN.

**User Interfaces (UI):** IADS prototype multi-function displays (MFDs) at ZFW TMU, D10 TMU, and the DFW East and West ATCTs were implemented in ATD-2 predecessor research and continue in use for field demo risk reduction and as the foundation for ATD-2 Phase 3. IADS MFDs will be implemented at the AAL-IOC and SWA-NOC. Finally, IADS MFDs are located in the NTX lab for system monitoring and technical support.

## 5.4 Washington ARTCC (ZDC) and Atlanta ARTCC (ZTL)

**General:** Figure 5.1 includes a box labeled “ZDC & ZTL” to denote the NASA installations at these facilities. During the ATD-2 field demonstration, the ZDC and ZTL TMCs’ primary interactions with the ATD-2 IADS prototype system will be via the FAA operational TBFM system. The TBFM/IADS interface is described in Section 4.3.1 and 4.3.2.

**Data Interfaces (DI):** None

**User Interfaces (UI):** IADS MFDs in the TMU to provide supplemental information during field demo operations and in the back-room area for shadow testing and training.

## **5.5 Charlotte Douglas International Airport (CLT)**

**General:** CLT is the primary site for the ATD-2 field demonstration. Multiple components of the IADS prototype system will be installed in various facilities at CLT including:

FAA Airport Traffic Control Tower (ATCT)

FAA Terminal RADAR Approach Control (TRACON)

American Airlines Ramp Tower (Hub Control Center)

CLT Airport Operations Center (Airport Ops)

NASA equipment rack in CLT New Terminal server room (Server Room)

NASA lab in CLT Old Terminal Building (CLT lab)

The IADS system components at CLT is linked via a NASA-managed Local Area Network (LAN) that leverages CLT Airport cable plant infrastructure (i.e., fiber and copper network cables) provided to NASA under terms of the CLT/NASA Space Act Agreement

The NASA NICS WAN shown in Figure 5.1 terminates in the Server Room where certain IADS prototype system core components run on rack-mounted servers.

**Data Interfaces (DI):** An interconnection between NASA and CLT Airport information systems to enable data exchange specified by the CLT/NASA Space Act Agreement.

**User Interfaces (UI):** Multi-functional Display which includes STBO and RTC/RMTC.

## **5.6 FAA William J Hughes Technical Center (WJHTC)**

**General:** The WJHTC is an FAA R&D, test, and evaluation facility located at Atlantic City International Airport (ACY). IADS prototype system data feed infrastructure and servers to support testing are located there.

**Data Interfaces (DI):** NAS Enterprise Security Gateway (NESG) connections to SWIM (FNTB and Ops), NASQuest proxy server, and TBFM proxy server. See Figure 5.2 for additional details.

**User Interfaces (UI):** IADS MFD in STBO lab to support testing.

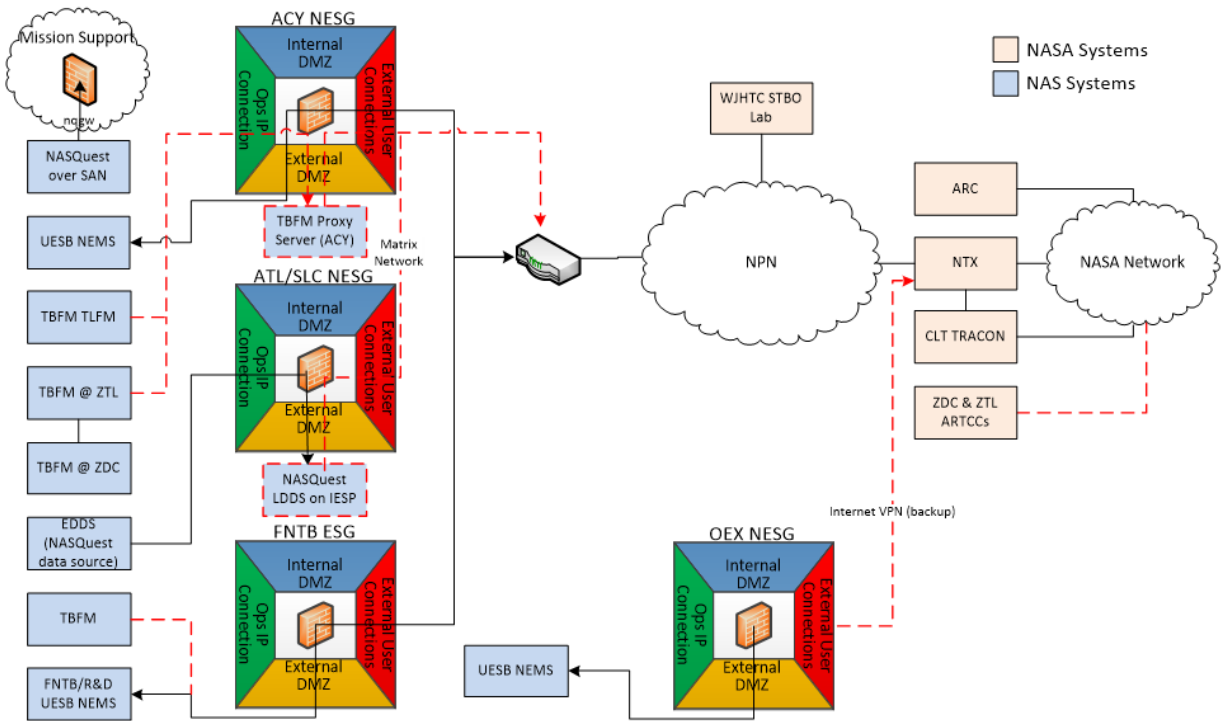

Figure 5.2 – This figure highlights the interfaces between FAA and NASA information systems for the ATD-2 field demonstration.

## 6 Summary

This document provided an overview of the technology for the Phase 1 Baseline and Phase 2 Fused IADS prototype system of NASA's ATD-2 project that is in field demonstration since the Fall of 2017 at Charlotte Douglas International Airport (CLT). Development, integration, and field demonstration of relevant technologies of the IADS system directly address recommendations made by the NextGen Integration Working Group (NIWG) on Surface and Data Sharing and the Surface CDM concept of operations developed jointly by the FAA and flight operators. NASA is conducting the ATD-2 research activity and field demonstrations in close coordination with the FAA, flight operator partners, CLT airport, and the National Air Traffic Controllers Association (NATCA).

The ATD-2 Phase 1 and Phase 2 capabilities consist of:

Strategic and tactical surface scheduling to improve efficiency and predictability of airport surface operations

Tactical departure scheduling to enhance merging of departures into overhead streams of traffic via accurate predictions of takeoff times and automated coordination between the Tower and the Center

Improvements in departure surface demand predictions in TBFM

A prototype EFD system (AEFS) provided by the FAA via the TFDM early implementation effort and its integration with ATD-2 IADS

Improved situational awareness and demand predictions through integration with TFMS, TBFM, and TFDM (3Ts) for electronic data integration and exchange and a dashboard displaying pertinent analytics in real-time

Data exchange and integration as well as data sharing

Fusion of strategic and tactical surface scheduling and metering

Expansion of airspace deployments to include adjacent Center automation

Integration of Mobile App and texting capability for GA/BA flights

Delivery of IADS data via the TFDM Terminal Publication (TTP) service of the FAA's SWIM system

Substantial improvements of RTC/RMTC functionalities

The various components of the IADS system have been deployed at the CLT ATC Tower, the CLT AAL Ramp Tower, ZDC, the American Airlines IOC, and the CLT Airport Operations. Deployment occurred in the summer of 2016 to support operational shadow evaluations prior to the actual Phase 1 demonstration beginning in 2017, and continuing into 2019 for Phase 2. A prototype TFDM SWIM data feed has been added to enable data sharing among stakeholders. The anticipated benefits through operational use of the IADS system include improved efficiency and predictability of surface and departure operations. These benefits will result in reduced delays, fuel savings, improved situational awareness, and a reduction in workload for the Tower and Center operations via 3T electronic data sharing and automation assisted coordination of flights. Also anticipated are increased situational awareness and reduced workload for the ramp personnel via pushback advisories and the use of new ramp user interfaces.

## 7 References

1. FAA Air Traffic Organization Surface Operations Directorate, “U.S. Airport Surface Concept of Operations (ConOps) in the Near-Term: Application of the Surface Concept at United States Airports,” June 2014.
2. NASA Airspace Technology Demonstration – 2 (ATD-2) Team, “ATD-2 Concept of Use (ConUse) for Charlotte Douglas International Airport for the Phase 1 Baseline Integrated Arrival, Departure, Surface (IADS) Demonstration,” v2.3, August 2017.
3. FAA, NextGen Update: 2016 website. (n.d.) Last retrieved 7 Aug 2016, from <https://www.faa.gov/nextgen/update/>
4. Engelland, S., Capps, A., Day, K., Kistler, M., Gaither, F., and Juro, G., “Precision Departure Release Capability (PDRC) Final Report,” NASA/TM-2013-216533, June 2013.
5. FAA, Decision Support Systems (DSS) Industry Forum, [https://www.faa.gov/about/office\\_org/headquarters\\_offices/ato/service\\_units/pmo/industry\\_day/media/day\\_1\\_-\\_dss\\_vision\\_rebecca\\_guy\\_-\\_final.pdf](https://www.faa.gov/about/office_org/headquarters_offices/ato/service_units/pmo/industry_day/media/day_1_-_dss_vision_rebecca_guy_-_final.pdf), 23 Apr 2014.
6. FAA, “TFDM Screening for Information Request (SIR): System Specification Document,” DCR-TFDM-009, 6 March 2015.
7. FAA, Air Traffic – Technology – TFDM website. (n.d.) Last retrieved 7 Aug 2016, from [http://www.faa.gov/air\\_traffic/technology/tfdm/](http://www.faa.gov/air_traffic/technology/tfdm/)
8. Hayashi, M., Hoang, T., Jung, Y., Malik, M., Lee, H., Dulchinos, V., “Evaluation of Pushback Decision-Support Tool Concept for Charlotte Douglas International Airport Ramp Operations,” 11<sup>th</sup> USA/Europe Air Traffic Management R&D Seminar (ATM2015), Lisbon, Portugal, June 23-26, 2015.
9. U.S. Dept. of Transportation/FAA, “Web Service Requirements Document (WSRD), Terminal Flight Data Manager (TFDM) Terminal Publication (TTP),” Version 2.0, 16 Aug 2016.
10. Lockheed Martin, “Airspace Technology Demonstration 2 (ATD-2) and TBFM Integration,” SIG Issue TBFM23605, 2 Feb 2017.
11. Lockheed Martin, “[TBFM23605 ATD-2 and TBFM Integration SIG Alternatives Review](#),” 18 July 2016.
12. “Enterprise Infrastructure Services (EIS) Assessment for NASA Airspace Technology Demonstration 2,” presentation to FAA Architecture Review Board, 8 Feb 2017.
13. Pinto, A. and Fuller, J., “Initial NextGen Test Bed Capabilities Analysis,” MITRE Technical Report MTR110171, April 2011.
14. Guy, R., “SWIM Partnerships: Collaboration with the FAA’s Decision Support Service (DSS) Programs,” SWIM Connect 2015, November 3, 2015.
15. Varcadipane, R., “FAA Traffic Flow Management, Surface Elements in TFMS Release 13,” Tech Workshop - Atlanta, June 2015.
16. NASA, “System Security Plan for the ARC Aeronautics Directorate Systems CD-999-M-ARC-3238,” January 2017.

17. National Institute of Standards and Technology, "Guide for Conducting Risk Assessments," NIST SP 800-30, Revision 1, September 2012.
18. National Institute of Standards and Technology, "Security and Privacy Controls for Federal Information Systems and Organizations," NIST SP 800-53, Revision 4, April 2013/Updates as of January 2015.
19. Coupe, W. J., Lee, Hanbong, Jung, Y., Chen, L., and Robeson, I., "Scheduling improvements following the Phase 1 field evaluation of the ATD-2 Integrated Arrival, Departure, and Surface Concepts" 13<sup>th</sup> USA/Europe Air Traffic Management Research and Development Seminar (ATM2019)



## A Appendix: IADS Operational Environment

Figure A.1 illustrates the operational environment for the IADS metroplex traffic management concept. The upper portion of the figure depicts en route airspace controlled by an Air Route Traffic Control Center (i.e., Center). The dashed line represents the boundary between the local Center, and one or more adjacent Centers. The cylinders in the lower portion of the figure represent terminal airspace. In the U.S., terminal airspace is often controlled by a TRACON facility. The larger cylinder on the left represents the local metroplex terminal airspace (situated in the local Center) for the IADS concept.

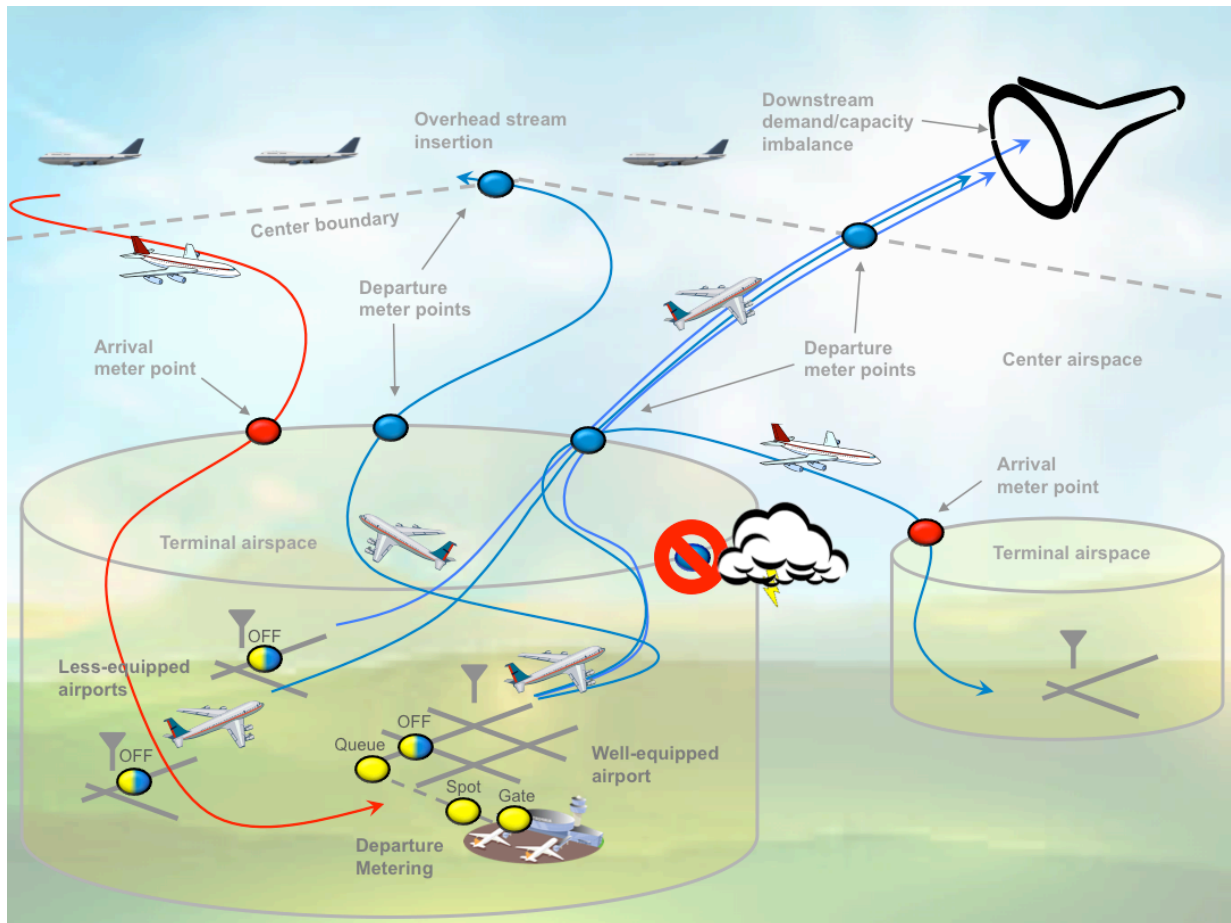

Figure A.1 - A simplified view of the ATD-2 project operational environment for the Phase 1 Baseline IADS Demonstration illustrates a variety of surface and airspace control points, plus impacts due to weather and downstream demand/capacity imbalances.

The smaller cylinder on the right represents a destination terminal airspace. The destination terminal airspace may be in the local Center, an adjacent Center, or even further downstream. Three airports are shown in the local terminal airspace: one well-equipped airport and two less-equipped airports.

Note that Figure A.1 has been simplified for illustration purposes. A metroplex can contain multiple airports that together can place significant departure demand on airspace resources. For example, the Northern California (NorCal) TRACON (NCT) metroplex features the large and well-equipped San Francisco International Airport (SFO), but also includes medium-sized, less-

equipped airports in Oakland (OAK) and San Jose (SJC), and numerous general aviation and military airports. Well-equipped airports are defined as those having comprehensive surveillance in the AMA, and therefore are capable of supporting trajectory-based surface automation. Typically, well-equipped airports are large and often subject to heavy demand from multiple flight operators. In addition, well-equipped airports will generally have more sophisticated automation aids in flight operator Ramp towers and FAA Towers (e.g., electronic flight strips) than their less-equipped counterparts.

Figure A.1 depicts trajectories departing from (blue) and arriving to (red) the local terminal airspace. The colored ovals illustrate some of the points (i.e., meter points) at which air traffic is scheduled, either by the automation or via manual procedures. Red ovals are arrival meter points. Blue ovals are departure meter points. Yellow ovals are surface meter points. The takeoff (i.e., OFF) points, represented by yellow and blue ovals, are important control points for the IADS concept, as they are the interface points between surface and airspace scheduling.

The funnel located at the top right of Figure A.1 represents a downstream demand/capacity imbalance that results in departure restrictions on the local terminal airspace. These restrictions could be applied at the meter point on the Center boundary and/or the departure fix at the terminal boundary (e.g., miles- or minutes-in-trail). Alternatively, the downstream traffic conditions could trigger strategic programs (e.g., a ground stop or ground delay) affecting departures from one or more airports in the local terminal airspace.

The thundercloud on the terminal boundary represents a typical dynamic weather event that may close one or more departure fixes, putting additional demand on fixes that remain open. The red arrival meter point entering a destination terminal airspace at the right of Figure A.1 shows how departures from the local terminal could also be subject to arrival metering constraints at their destination, even prior to takeoff.

## B Appendix: ATD-2 Project Field Demonstration Strategy

The ATD-2 project field demonstration is organized into three phases, as depicted in Figure B.1, which is an excerpt from the ATD-2 Integrated Master Schedule (IMS). The figure shows that the series of operational evaluation and use periods are set to begin in September 2017 and run continuously through September 2020. The IADS system capability increases with each phase of the evaluation, and each phase is preceded by shadow evaluation periods during which system readiness will be assessed. The shadow evaluation periods and the associated readiness decision points are indicated by the blue and green callouts in Figure B.1. The gold stars on the schedule denote schedule commitments that NASA has made to their field demonstration partners.

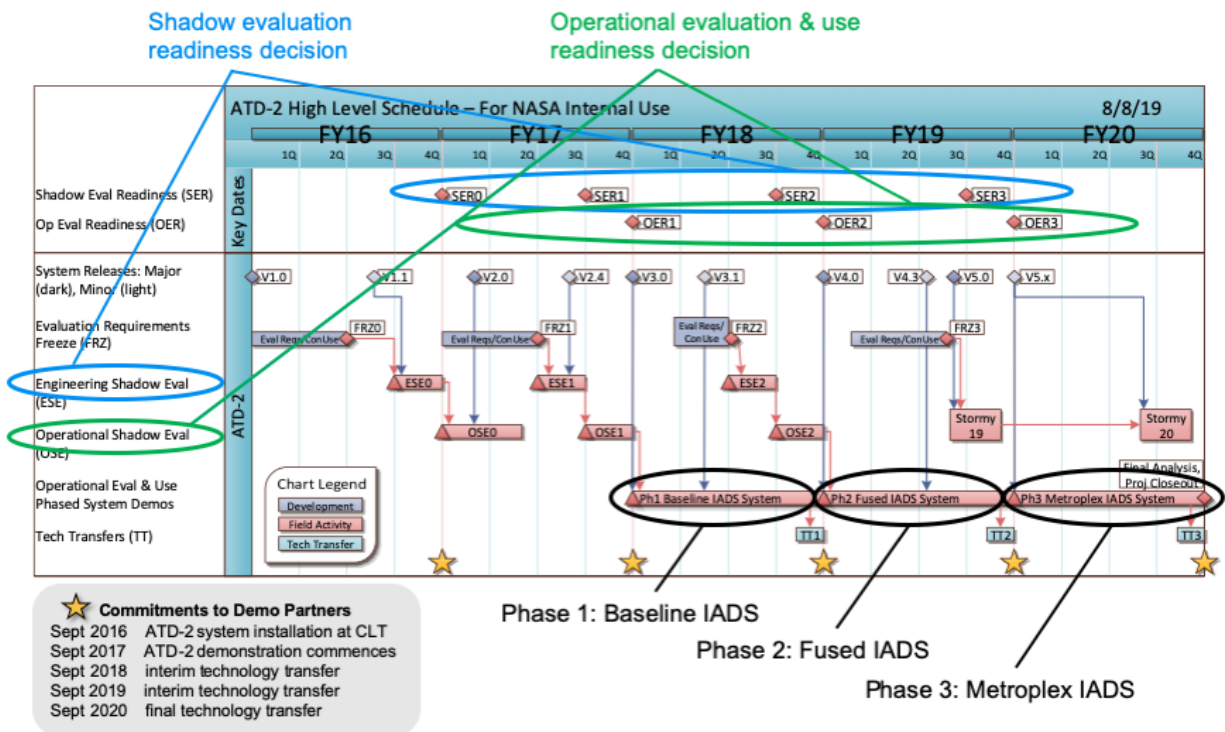

Figure B.1 - The ATD-2 project employs a field demonstration strategy built upon three distinct phases, each representing an increased system capability.

The following subsections provide more information on each of the demonstration phases.

### B.1 Phase 1: Baseline IADS

The Phase 1 Baseline IADS Demonstration include all the components of IADS running in an operational environment, illustrated in Figure B.2. It provides the initial integrated capability demonstration of (1) de-coupled tactical surface scheduling and predictive strategic surface scheduling, (2) tactical departure scheduling to an en route meter point, (3) improved departure surface demand predictions, and (4) a prototype EFD provided by the FAA via the TFDM early implementation effort. In addition, during the Phase 1 demonstration, a prototype TFDM SWIM data feed was incorporated.

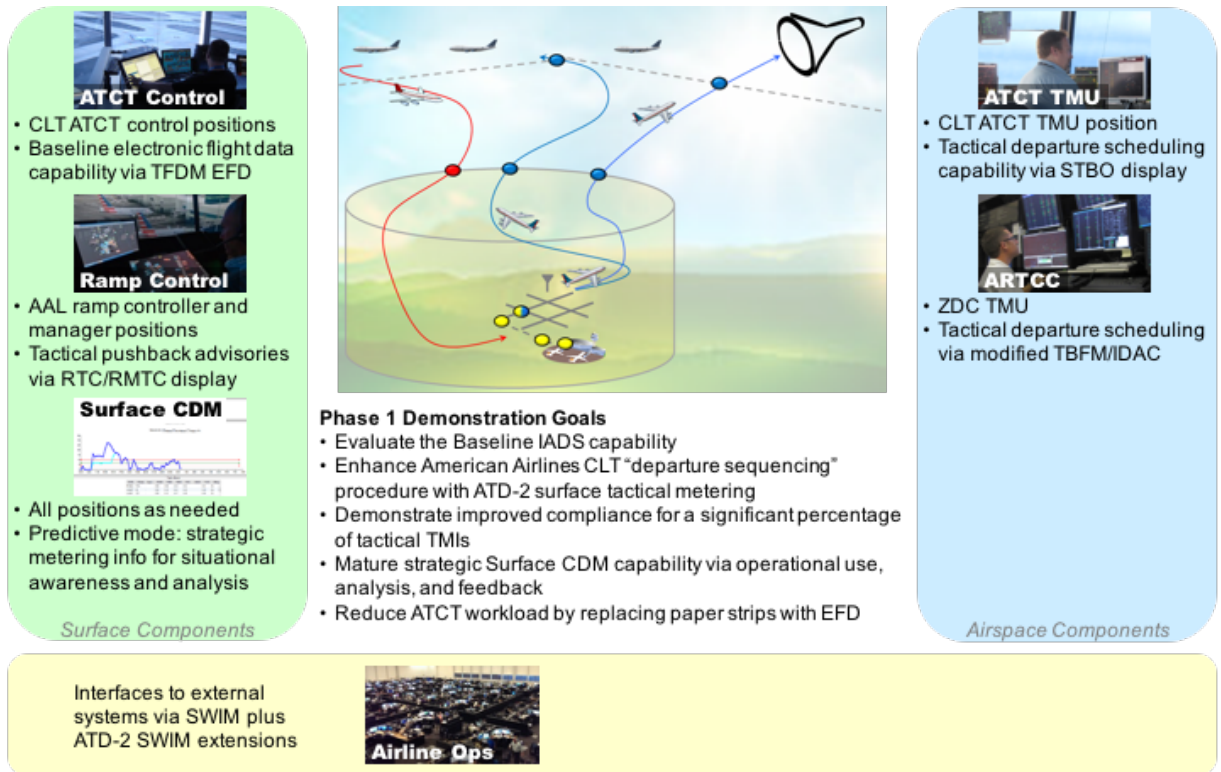

Figure B.2 - This operational overview of the IADS system highlights both the participants at various facilities and the system improvements for the Phase 1 Baseline IADS Demonstration.

## B.2 Phase 2: Fused IADS

The system used to support the Baseline IADS Demonstration was enhanced and expanded in significant ways to support the Fused IADS Demonstration, illustrated in Figure B.3. Principal characteristics and key functionality of the Fused IADS Demonstration that will differentiate it from the Baseline IADS are:

Prescriptive\* strategic surface scheduling.

Fusion of strategic and tactical surface scheduling capabilities.

Expansion of airspace deployments to include adjacent Center automation.

Substantial updates to the Baseline IADS Demonstration capability, including updates to tactical surface scheduling, tactical departure scheduling, surface metering, Electronic Flight Data (EFD) by implementing a two-way, real-time interface with AEFS, RTC/RMTC, departure trajectories, TFDM SWIM prototype feed by means of TTP, and integration of the Mobile App system for General Aviation flight data.

---

\* Prescriptive is used here to indicate that the strategic system metering advisories will be used to meter traffic in situations with significant demand/capacity imbalances. Fused system tactical pushback advisories will honor strategic TMATs.

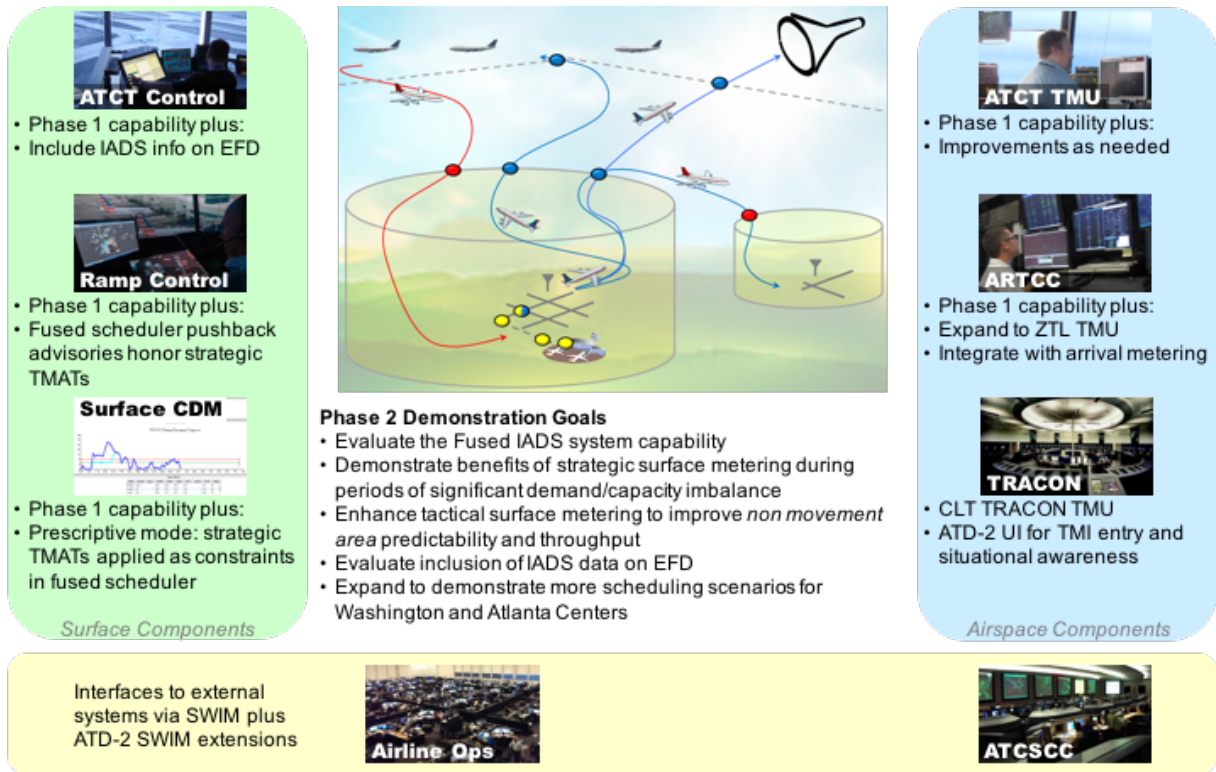

Figure B.3 - This enhanced operational overview of the IADS system highlights both the participants at various facilities and the system improvements for the Phase 2 Fused IADS Demonstration.

Figure B.4 depicts a summary of the ATD-2 IADS Phase 2 capabilities.

**Integrated Arrival, Departure, Surface (IADS) System v4.0**  
*deployed: September 11<sup>th</sup> ✓*

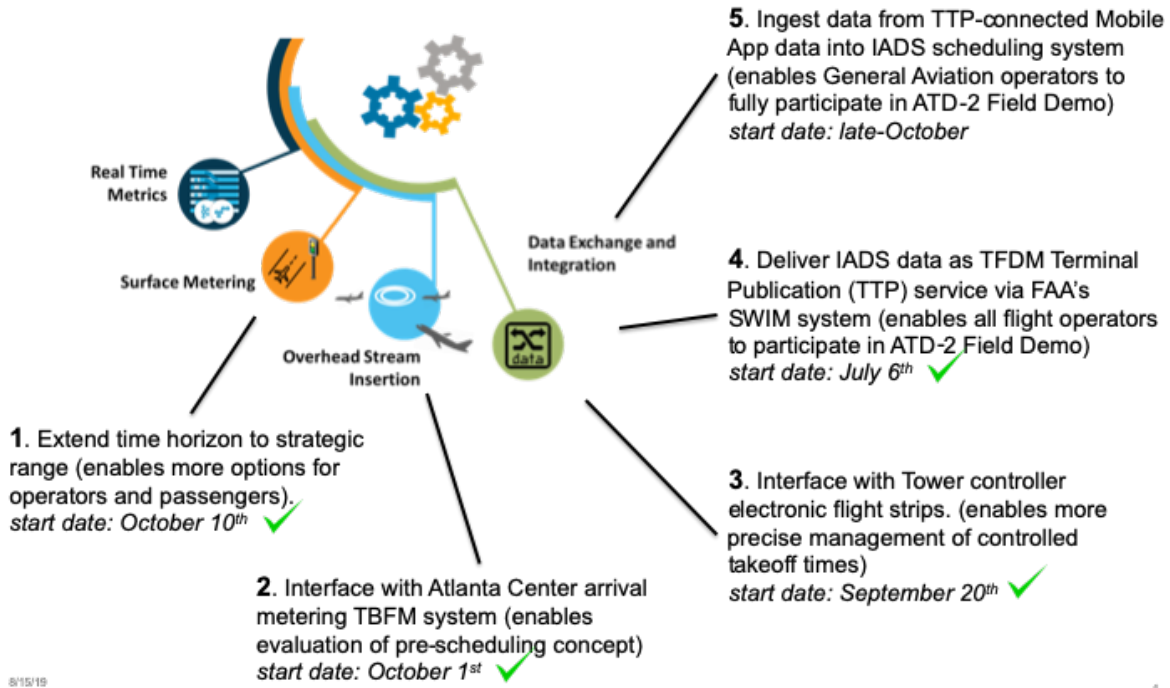

Figure B.4 - ATD-2 Phase 2 capabilities summary.

**B.3 Phase 3: Metroplex IADS**

The Metroplex IADS Demonstration represents the culmination of the IADS system capability as demonstrated in field and high-fidelity simulation, illustrated in Figure B.5. It incorporates the IADS tactical departure scheduling for the metroplex and integrates Tower electronic flight data with IADS scheduling (both surface and airspace).

Principal characteristics and key functionality of the Metroplex IADS Demonstration that will differentiate it from the Fused IADS are:

Improvements resulting from data received during strategic expansion. Substantial updates to the Fused IADS Demonstration capability, including tactical surface scheduling, tactical departure scheduling, EFD, RTC/RMTC, departure trajectories including Trajectory Option Set (TOS) for re-routing flights and TFDM SWIM prototype feed and TTP as well as expansion of Mobile App technology for GA flights.

IADS terminal departure scheduling from multiple airports to outbound TRACON meter points in a relevant operational environment.

High-fidelity demonstration of all integrated system capabilities.

Trajectory Option Set (TOS) design and implementation for flights within Terminal airspace.



**ATCT Control**

- Phase 2 capability plus:
- Integrate EFD with ATD-2 scheduling and metering

**Ramp Control**

- Phase 2 capability plus:
- Improvements as needed

**Surface CDM**



- Phase 2 capability plus:
- Improvements as needed

*Surface Components*

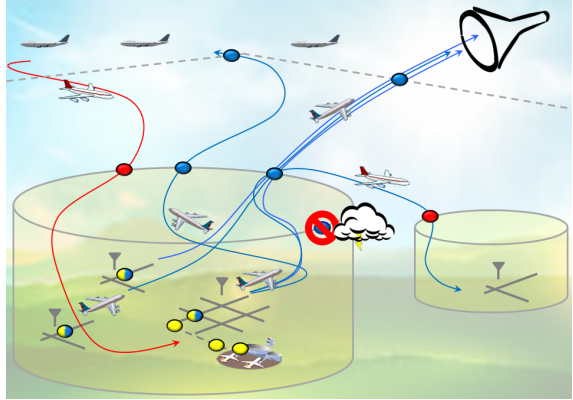

**Phase 3 Demonstration Goals**

- Evaluate the Metroplex IADS system capability
- Integrate EFD with ATD-2 scheduling
- Mature and enhance core ATD-2 capabilities
- Enhance CLT tactical surface metering to improve *movement area* predictability and throughput
- Reduce delay and increase throughput under Metroplex departure constraints [NOTE: Metroplex Coordinator to be demonstrated for DFW TRACON (D10) environment via HITL or field experiment]

**ATCT TMU**

- Phase 2 capability plus:
- Improvements as needed

**ARTCC**

- Phase 2 capability plus:
- Improvements as needed

**TRACON**

- Phase 2 capability plus:
- Metroplex Planner implemented for DFW TRACON (D10) environment

*Airspace Components*

Interfaces to external systems via SWIM plus ATD-2 SWIM extensions

**Airline Ops**      **Airport Ops**      **Industry Apps**      **ATCSCC**

1

Figure B.5 - This full operational overview of the IADS system highlights both the participants at various facilities and the system improvements for the Phase 3 Metroplex IADS Demonstration.

## C Appendix: Surface Data Elements

This appendix provides additional information on the 11 surface data elements that the flight operators have committed to supplying via TFMS Release 13, illustrated in Figure C.1. Descriptive information on the surface data elements was taken from FAA SWIM Connect 2015.<sup>14</sup>

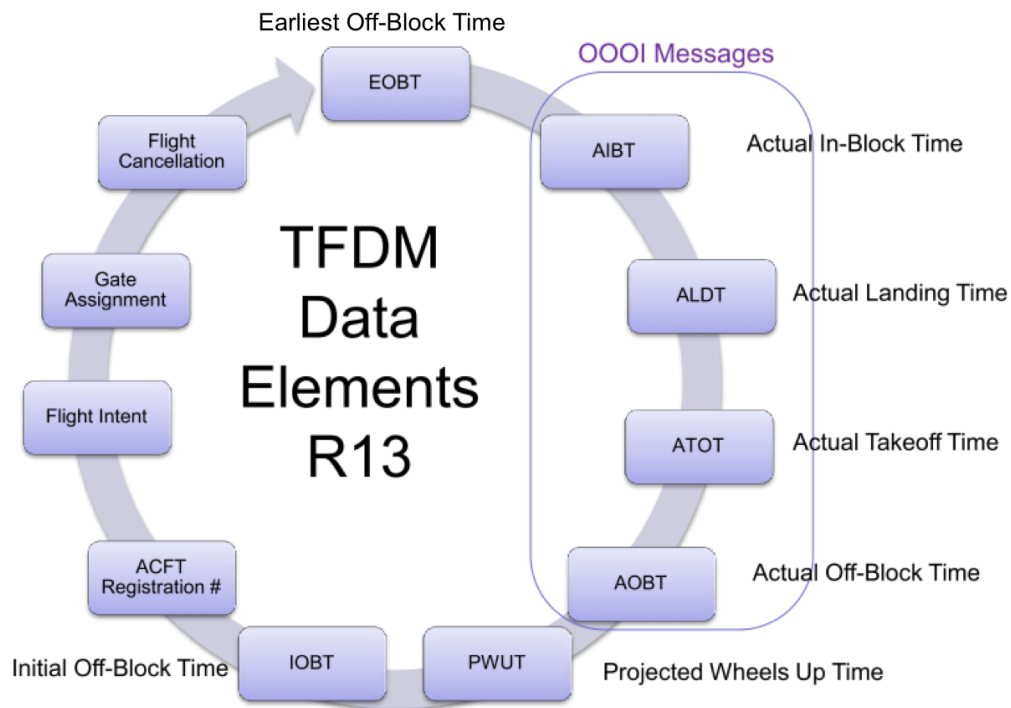

Figure C.1 – These 11 surface data elements will be provided via TFMS Release 13.<sup>15</sup>

### C.1 Actual Off-Block Time (AOBT)

The time when an aircraft pushes back from its assigned gate or parking location, or when it commences movement with the intent to taxi for departure, will be reported by the flight operator. This is the actual time at which the flight has sent a 'block out' message from the gate or parking location. This information will be used to help determine the accuracy of a flight operator's Earliest Off-Block Time (EOBT).

Expected TFDM Use:

- Update surface scheduling system based on AOBT
- Update flight state data for sharing with external systems
- Update flight state to evaluate gate availability

Expected Operational Benefits:

- Improved surface scheduler accuracy
- Sharing of flight state data to improve situational awareness for TRACON/ARTCC



Updated gate availability needed to reduce gate conflicts and manage demand/capacity imbalances

### **C.2 Actual Takeoff Time (ATOT)**

The time at which a flight lifts off from the runway (i.e., wheels up time, when the flight becomes airborne) will be reported by the flight operator or by TRACON automation. If more than one value is sent, the most recently submitted time will be contained in this field. Otherwise, the value will be null. This time stops the Department of Transportation (DOT3) time for departing flights.

Expected TFDM Use:

Update surface scheduling system based on ATOT

Update flight state data for sharing with external systems

Expected Operational Benefits:

Improved surface scheduler accuracy

Sharing of flight state data to improve situational awareness for TRACON/ARTCC

### **C.3 Actual Landing Time (ALDT)**

The actual time that an arriving flight lands on the runway will be provided by the flight operator. Sharing arrival information provides essential information to facilitate gate conflict and demand/capacity imbalance predictions. This element is the DOT3 arriving aircraft time trigger.

Expected TFDM Use:

Update flight state data to evaluate gate availability

Expected Operational Benefits:

Updated gate availability needed to reduce gate conflicts and manage demand/capacity imbalances

### **C.4 Actual In-Block Time (AIBT)**

The actual time that a flight reaches its gate or parking stand (i.e., the flight has blocked in at the gate) will be provided by either the flight operator or the aircraft surface surveillance. Sharing arrival information provides essential information to facilitate both gate conflict predictions and demand/capacity imbalance predictions.

Expected TFDM Use:

Update flight state data to evaluate gate availability

Expected Operational Benefits:

Updated gate availability needed to reduce gate conflicts and manage demand/capacity imbalances

### **C.5 Aircraft Tail/Registration #**

The flight operator will provide a unique, alphanumeric string that identifies a civil aircraft (e.g., N1237A), consisting of the Aircraft Nationality or Common Mark and an additional

alphanumeric string assigned by the state of registry or common mark registering authority.  
"Aircraft Registration Mark" in FIXM Core.

Expected TFDM Use:

Enable gate conflict and demand/capacity imbalance monitoring by connecting arrival flight information to related departure flight information

Expected Operational Benefits:

System can detect and alert when changes to an arrival flight's schedule may impact a departure flight's schedule

### **C.6 Earliest Off-Block Time (EOBT)**

The earliest time a flight would be able to push back from its gate or taxi from its parking stand for departure in the absence of metering will be provided by either the Ramp Control personnel or the flight operator. The system can forecast surface demand vs. capacity, based on the flight operator's best estimation of push back time. The fidelity of the EOBT is required for proper surface predictions and processes.

Expected TFDM Use:

Update surface scheduling system based on EOBT data

Use to evaluate demand/capacity imbalances and need for metering

Expected Operational Benefits:

Improved surface scheduler accuracy

Improved demand predictions

Improved resource utilization via metering

### **C.7 Flight Cancellation**

The flight operator will send a message that indicates a flight has been cancelled, specifically to ensure that resources are not engaged and/or fully utilized for it.

Expected TFDM Use:

Update demand predictions

Allow stakeholders to substitute other flights in place of cancellations

Expected Operational Benefits:

Improved demand predictions to ensure metering programs fully utilize capacity

Provide users flexibility to utilize capacity from cancelled flights to meet business objectives

### **C.8 Flight Intent**

The flight intent information provides common situational awareness about a specific flight with regard to de-icing at the ramp/AMA or the gate, holding at the ramp or in the AMA, or an expected gate return or pushback times. Any plans with this intent will be provided by the flight operator.

Expected TFDM Use:

Provide system alerts to ATC of flights intending to de-ice, hold, push back early, or return to the gate

Expected Operational Benefits:

Situational awareness for ATC to identify flights intending to:

- De-ice in the AMA/ramp or the gate area
- Push back early that need to hold in either the ramp or the AMA until the expected times
- Return to the gate or provide a pushback time

### **C.9 Gate Assignment**

The Flight or Airport Operator gate assignment for a flight will be provided to lead to more accurate Ramp Transit Time (RTT) calculations, and therefore, a more accurate Estimated Time of Departure (ETD).

Expected TFDM Use:

Update demand predictions

Expected Operational Benefits:

Earlier detection of potential gate conflicts

More accurate ETD calculation to improve compliance with control times

Improve accuracy of surface metering predictions

### **C.10 Initial Off-Block Time (IOBT)**

The initial off-block time for a flight will be provided by the flight operator. This data element will be used to save the original off-block time of the flight, and will be useful for flight data matching.

Expected TFDM Use:

Use IOBT to identify initial resource demand

Expected Operational Benefits:

Improved surface scheduler accuracy

### **C.11 Earliest Runway Time of Departure (ERTD)**

The flight operator estimate of runway departure time will not include any traffic management initiatives. Thus, it is a projection of non-TMI aircraft wheels up time.

Expected TFDM Use:

Update demand estimates and predictions

Expected Operational Benefits:

TFDM will provide a higher-fidelity version of ERTD at airports with TFDM surface automation

May still be useful at those airports with no (or minimal) TFDM capabilities

## D Appendix: Security, NEXUS, and Interfaces

This appendix provides background information on the NASA information system security plan that applies to ATD-2 IADS system installations.

NASA information systems supporting the ATD-2 field demonstration are elements of an information system owned by the Aeronautics Directorate at NASA Ames Research Center (ARC). The relevant NASA security plan is identified as “System Security Plan for the ARC Aeronautics Directorate Systems CD-999-M-ARC-3238.”<sup>16</sup> Per NIST SP 800-30,<sup>17</sup> the ARC Aeronautics Directorate Systems have been designated as MODERATE, and corresponding security controls are implemented per NIST SP 800-53.<sup>18</sup>

The security plan includes an abstraction known as the NextGen Emulation System (NEXUS) research platform (see Figure D.1) which addresses the case of NASA information systems embedded in research partner (e.g., FAA and flight operator) operational facilities.

### NTX NextGen Emulation System (NEXUS) High Level System Context Diagram

- **NEXUS** is a research platform (depicted in flight test orange) and not intended for operational deployment. It links several air traffic management systems to emulate a subset of NextGen capabilities in today’s environment.
- **DI** -- Data Interfaces for operational automation systems & DSTs (e.g., TBFM, TFMS, gate mgmt systems, ramp mgmt systems, commercial surface apps, etc.)
- **UI** -- User Interfaces facilitate research collaboration prior to integration with operational automation systems

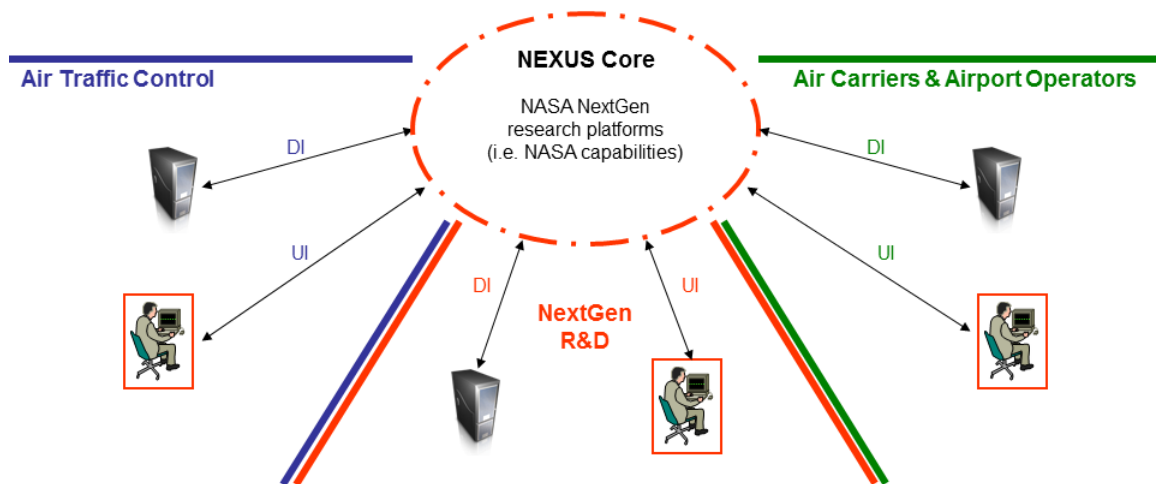

Figure D.1 - NASA’s information system security plan uses the NextGen Emulation system (NEXUS) abstraction to define system boundaries and two classes of system interfaces.

Applying the NEXUS abstraction to ATD-2 field demonstration installations we find that core components of the ATD-2 IADS system reside in the “NEXUS core” illustrated by the dashed oval in Figure D.1. These core components are physically implemented on NASA information systems at NTX and CLT. The ATD-2 IADS system utilizes both types of interfaces depicted in the NEXUS diagram and described below:

Data Interface (DI)

Involves an interconnection between NASA and research partner information systems

Protected with appropriate safeguards (i.e., firewalls) and agreements

IADS examples: SWIM interface at NESG, TBFM proxy server, NASQuest, AAL FlightHub, MITRE, etc.

#### User Interface (UI)

Involves an extension of the NASA information system (i.e., network) into the research partner facility but does NOT involve interconnections

May utilize research partner physical cable plant elements (e.g., fiber or copper runs), but these are fully-dedicated for NASA use and carry no other logical networks

IADS user interfaces are described as multi-function displays (MFDs) because they are capable of displaying numerous user interfaces from IADS component systems

IADS examples: MFDs at the ATC Tower (back room and cab), Center (back room and TMU), Ramp Tower, Airport Operations, etc.

## E Appendix: Acronyms

This appendix contains acronyms that are used repeatedly throughout this ConUse as well as the ATD-2 Phase 1 Baseline IADS and Phase 2 Fused IADS demonstrations.

<b>Acronym</b>	<b>Term</b>
3D	Three-Dimensional
3Ts	FAA's TBFM, TFMS, and TFDM
AAL	American Airlines
AAR	Airport Arrival Rate
ACFT	Aircraft
ADR	Airport Departure Rate
ADW	Arrival Departure Window
AEFS	Advanced Electronic Flight Strip
AFP	Airspace Flow Program
AIBT	Actual In-Block Time
AIXM	Aeronautical Information Exchange Model
ALDT	Actual Landing Time
AMA	Airport Movement Area
AMAT	Actual Movement Area entry Time
AOBT	Actual Off-Block Time
AODB	Airlines Operational Database
APREQ/CFR	Approval Request/Call for Release
ARCR	Airport Resource Capacity Rates
ARM	Airport Resource Management
ARMD	Aeronautics Research Mission Directorate (NASA)
ARMT	Airport Resource Management Tool
ARTCC, or Center	Air Route Traffic Control Center
ASDE-X	Airport Surface Detection Equipment – Model X
ASDI	Aircraft Situation Display to Industry
ATC	Air Traffic Control
ATCSCC, or Command Center	Air Traffic Control System Command Center
ATCT, or Tower	Airport Traffic Control Tower
ATD-1	ATM Technology Demonstration 1
ATD-2	Airspace Technology Demonstration 2
ATG	Airspace Target Generator
ATL	Hartsfield-Jackson Atlanta International Airport
ATM	Air Traffic Management
ATOT	Actual Takeoff Time
CAP	Collaborative Arrival Planning
CD	Clearance Delivery
CDM	Collaborative Decision Making
CDR	Coded Departure Route
CLE	Cleveland Hopkins International Airport
CLT	Charlotte Douglas International Airport

<b>Acronym</b>	<b>Term</b>
CMS	Controller Managed Spacing
ConOps	Concept of Operations
ConUse	Concept of Use
CPDLC	Controller-Pilot Data Link
CRO	Converging Runway Operations
CSP	Constraint Satisfaction Point
CTD	Controlled Time of Departure
CTOT	Controlled Take-Off Time
D0	Common flight operator on-time departure metrics
DFW	Dallas/Fort Worth International Airport
DCL	Departure Clearance
DFSN	Data Fusion
DI	Data Interface
DOT	Department of Transportation
DRC	Departure Reservoir Coordinator
DRM	Departure Reservoir Management
DSP	Departure Sequencing Program
DSS	Decision Support Systems/Decision Support Service
DST	Decision Support Tool
EDC	En route Departure Capability
EDCT	Expect Departure Clearance Time
EDIF	ETMS Data Interface
EFD	Electronic Flight Data
EFSTS	Electronic Flight Strip Transfer System
EFTT	Earliest Feasible Takeoff Time
EOBT	Earliest Off-Block Time
ERAM	En Route Automation Modernization
ERTD	Earliest Runway Time of Departure
ETA	Estimated Time of Arrival
ETD	Estimated Time of Departure
ETMS	Enhanced Traffic Management System
ETOT	Estimated Takeoff Time
EWR	Newark Liberty International Airport
FAA	Federal Aviation Administration
FCFS	First-Come, First-Served
FDIO	Flight Data Input/output
FFC	Future Flight Central
FID	Final Investment Decision
FIXM	Flight Information Exchange Model
FLM	Front Line Manager
FMC	Flight Management Connector
FOSA	Flight Operations Surface Application
FSFS	First-Scheduled, First-Served
GA	General Aviation



<b>Acronym</b>	<b>Term</b>
GC	Ground Controller
GDP	Ground Delay Program
GS	Ground Stop(s)
GUFI	Globally Unique Flight Identifier
GUI	Graphical User Interface
HITL	Human-in-the-Loop
IADS	Integrated Arrival, Departure, and Surface
ID	Identification
IDAC	Integrated Departure Arrival Capability (TBFM)
IDS	Integrated Display System
IDST	Integrated Departure Scheduling Tool
IMC	Instrument Meteorological Condition
IMS	Integrated Master Schedule
IN	Arrival at Gate
IOBT	Initial Off-Block Time
IOC	Integrated Operations Center
ISAS	Integrated Surface and Airspace Simulation
J-22	TFDM Specification Artifact
JFK	John F. Kennedy International Airport
JMS	Java Message Service
LAS	<i>Las Vegas McCarran International Airport</i>
LC	Local Controller
LGA	LaGuardia Airport
LOB	Long on Board
MIT	Miles-in-Trail
MP	Metroplex Planner
MRA	Metrics, Reporting & Analysis (DRM component)
NAC	NextGen Advisory Committee (FAA)
NAS	National Airspace System
NASA	National Aeronautics and Space Administration
NATCA	National Air Traffic Controllers Association
NCT	Northern California (NorCal) TRACON
NextGen	Next Generation Air Transportation System
NIWG	NextGen Integration Working Group
NM	Nautical Miles
NorCal	Northern California
NPN	NASA/FAA Private Network
NTML	National Traffic Management Log
NEXUS	NextGen Emulation System
OAK	Metropolitan Oakland International Airport
OER	Operational Evaluation Report
OFF	Departure at Runway
OIS	Operational Information System
ON	Arrival at Runway

<b>Acronym</b>	<b>Term</b>
OpNec	Operational Necessity
OUT	Departure off Gate
OV-1	High Level Operational View
P3	Process, Procedures and Policies
PDC	Pre-departure Clearance
PDRC	Precision Departure Release Capability
PGUI	Planview Graphical User Interface
PHX	Phoenix Sky Harbor International Airport
PIC	Pilot in Command
R&D	Research and Development
R&T	Research and Technology
R13	TFMS Release 13
RBS	Ration by Schedule
RDR	Runway Departure Rate
RFRT	Request for a Release Time
RMTC	Ramp Manager Traffic Console
RTBFM	Research TBFM
RTC	Ramp Traffic Console
RTT	Ramp Transit Time
RTT	Research Transition Team
SARDA	Spot and Runway Departure Advisor
SDSS	Surface Decision Support System
SDT	Scheduled Departure Time
SFDPS	SWIM Flight Data Publication Service
SFO	San Francisco International Airport
SID	Standard Instrument Departure
SIG	Systems Issues Group
SIR	Screening Information Request
SJC	Norman Y. Mineta San Jose International Airport
SMA	Surface Movement Advisor
SME	Subject Matter Expert
SMS	Surface Management System
SOBT	Scheduled Off-Block Time
SRR	System Requirements Review
STA	Scheduled Time of Arrival
STARS	Standard Terminal Automation Replacement System
STBO	Surface Trajectory Based Operations
STDDS	SWIM Terminal Data Distribution System
Surface CDM	Surface Collaborative Decision Making
SWIM	System Wide Information Management
T2T	TBFM-to-TBFM
TBD	To Be Determined
TBFM	Time Based Flow Management System
TBO	Trajectory Based Operations

<b>Acronym</b>	<b>Term</b>
TDD	Technology Description Document
TDLS	Tower Data Link Service
TFD	Traffic Flow Data Management
TFDM	Terminal Flight Data Manager
TFM	Traffic Flow Management
TFMDI	TFM Data to Industry
TFMS	Traffic Flow Management System
TGUI	Timeline Graphical User Interface
TMA	Traffic Management Advisor
TMAT	Target Movement Area entry Time
TMC	Traffic Management Coordinator
TMI	Traffic Management Initiative
TMU	Traffic Management Unit
TOBT	Target Off-Block Time
TOS	Trajectory Option Set
TRACON	Terminal RADAR Approach Control
TS	Trajectory Synthesizer
TSAS	Terminal Sequencing and Spacing (formerly TSS)
TSLE	Terminal Second Level Engineering (AJM-24)
TTOT	Target Take-Off Time
UDP	Unified Delay Program
UI	User Interface
ULDT	Undelayed Landing Time
UTOT	Undelayed Takeoff Time
VMC	Visual Meteorological Condition
WJHTC	William J. Hughes Technical Center
WS	Web Services
WSRD	Web Services Requirements Document
WSRT	Web Service Requirements Tool
XML	Extensible Markup Language
XSD	XML Schema
ZDC	Washington Air Route Traffic Control Center
ZTL	Atlanta Air Route Traffic Control Center